

# **marantz®**

**Model PV5580/PV6080 User Guide**

---

**HD Widescreen Television**



# Return your Warranty Registration card today to ensure you receive all the benefits you're entitled to.

Once your MARANTZ purchase is registered, you're eligible to receive all the privileges of owning a MARANTZ product. So complete and return the Warranty Registration Card enclosed with your purchase at once. And take advantage of these important benefits.

<h3>Warranty Verification</h3> <p>Registering your product within 10 days confirms your right to maximum protection under the terms and conditions of your MARANTZ warranty.</p>	<h3>Owner Confirmation</h3> <p>Your completed Warranty Registration Card serves as verification of ownership in the event of product theft or loss.</p>	<h3>Model Registration</h3> <p>Returning your Warranty Registration Card right away guarantees you'll receive all the information and special offers which you qualify for as the owner of your model.</p>
--	---	--

**For Customer Use**

Enter below the Serial Number which is located on the rear of the cabinet. Retain this information for future reference.

Model Number: \_\_\_\_\_ Serial Number: \_\_\_\_\_

*Know these*  
**safety symbols**



This "bolt of lightning" indicates uninsulated material within your unit which may cause an electrical shock. For the safety of everyone in your household, please do not remove product covering.

The "exclamation point" calls attention to features for which you should read the enclosed literature closely to prevent operating and maintenance problems.

WARNING: TO PREVENT FIRE OR SHOCK HAZARD, DO NOT EXPOSE THIS EQUIPMENT TO RAIN OR MOISTURE.

CAUTION: To prevent electric shock, match wide blade of plug to wide slot, and fully insert.

ATTENTION: Pour éviter les chocs électriques, introduire la lame la plus large de la fiche dans la borne correspondante de la prise et pousser jusqu'au fond.

# SAFETY INSTRUCTIONS - Read before operating equipment

This product was designed and manufactured to meet strict quality and safety standards. There are, however, some installation and operation precautions which you should be particularly aware of.

1. **Read Instructions** - All the safety and operating instructions should be read before the appliance is operated.
2. **Retain Instructions** - The safety and operating instructions should be retained for future reference.
3. **Heed Warnings** - All warnings on the appliance and in the operating instructions should be adhered to.
4. **Follow Instructions** - All operating and use instructions should be followed.
5. **Water and Moisture** - The appliance should not be used near water - for example, near a bathtub, washbowl, kitchen sink, laundry tub, in a wet basement or near a swimming pool, etc.
6. **Carts and Stands** - The appliance should be used only with a cart or stand that is recommended by the manufacturer.
- 6A.  An appliance and cart combination should be moved with care. Quick stops, excessive force, and uneven surfaces may cause the appliance and cart combination to overturn.
- 6B. **Tilt/Stability** - All televisions must comply with recommended international global safety standards for tilt and stability properties of its cabinet design.
  - Do not compromise these design standards by applying excessive pull force to the front, or top, of the cabinet which could ultimately overturn the product.
  - Also, do not endanger yourself, or children, by placing electronic equipment/toys on the top of the cabinet. Such items could unsuspectingly fall from the top of the set and cause product damage and/or personal injury.
7. **Wall or Ceiling Mounting** - The appliance should be mounted to a wall or ceiling only as recommended by the manufacturer.
8. **Ventilation** - The appliance should be situated so that its location or position does not interfere with its proper ventilation. For example, the appliance should not be situated on a bed, sofa, rug, or similar surface that may block the ventilation openings; or, placed in a built-in installation, such as a bookcase or cabinet that may impede the flow of air through the ventilation openings.
9. **Heat** - The appliance should be situated away from heat sources such as radiators, heat registers, stoves, or other appliances (including amplifiers) that produce heat.
10. **Power Sources** - The appliance should be connected to a power supply only of the type described in the operating instructions or as marked on the appliance.

11. **Power-Cord Protection** - Power supply cords should be routed so that they are not likely to be walked on or pinched by items placed upon or against them, paying particular attention to cords and plugs, convenience receptacles, and the point where they exit from the appliance.
12. **Cleaning** - The appliance should be cleaned only as recommended by the manufacturer.
13. **Power Lines** - An outdoor antenna should be located away from power lines.
14. **Outdoor Antenna Grounding** - If an outside antenna is connected to the receiver, be sure the antenna system is grounded so as to provide some protection against voltage surges and built up static charges.  
Section 810 of the National Electric Code, ANSI/NFPA No. 70-1984, provides information with respect to proper grounding of the masts and supporting structure grounding of the lead-in wire to an antenna discharge unit, size of grounding connectors, location of antenna-discharge unit, connection to grounding electrodes and requirements for the grounding electrode. See Fig. below.
15. **Non-use Periods** - The power cord of the appliance should be unplugged from the outlet when left unused for a long period of time.
16. **Object and Liquid Entry** - Care should be taken so that objects do not fall and liquids are not spilled into the enclosure through openings.
17. **Damage Requiring Service** - The appliance should be serviced by qualified service personnel when:
  - A. The power supply cord or the plug has been damaged; or
  - B. Objects have fallen, or liquid has been spilled into the appliance; or
  - C. The appliance has been exposed to rain; or
  - D. The appliance does not appear to operate normally or exhibits a marked change in performance; or
  - E. The appliance has been dropped, or the enclosure damaged.
18. **Servicing** - The user should not attempt to service the appliance beyond that described in the operating instructions. All other servicing should be referred to qualified service personnel.

**Note to the CATV system installer:** This reminder is provided to call the CATV system installer's attention to Article 820-40 of the NEC that provides guidelines for proper grounding and, in particular, specifies that the cable ground shall be connected to the grounding system of the building, as close to the point of cable entry as practical.

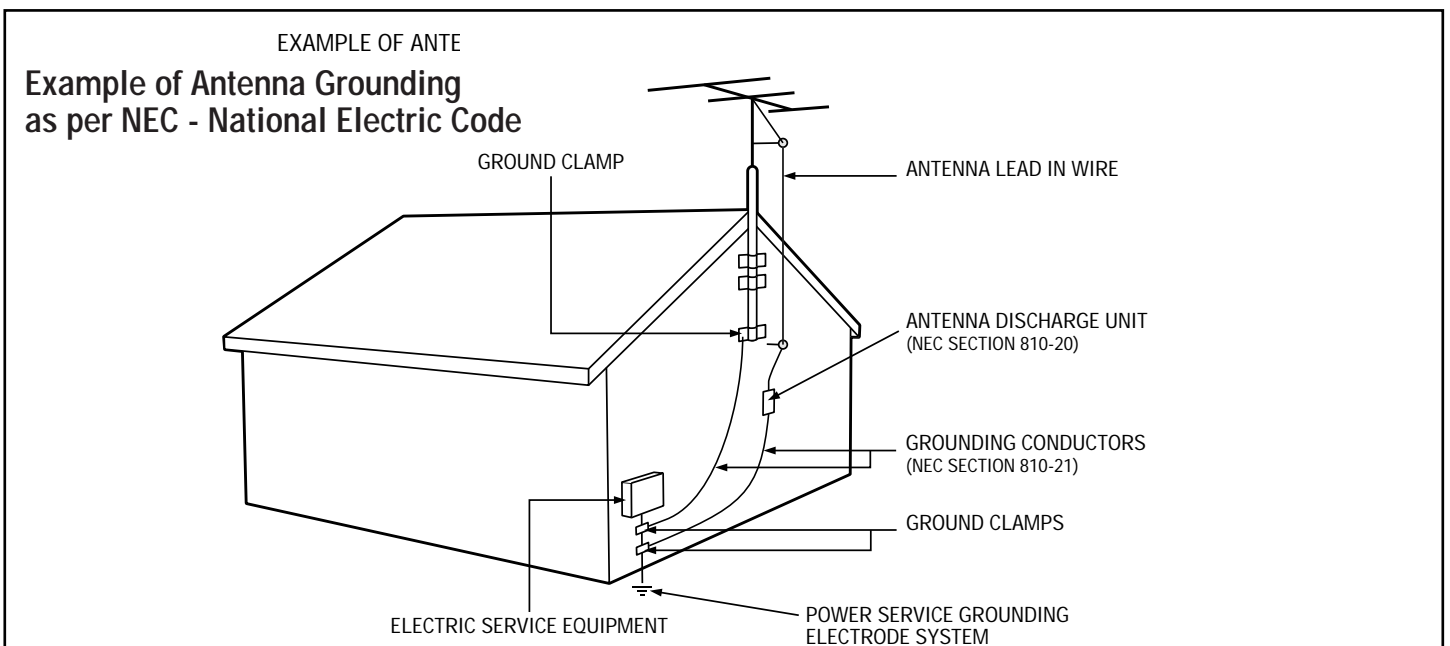

# TABLE OF CONTENTS



## **Getting Started**

Welcome/Product Registration .....	2
Safety/Precautions .....	3
Table of Contents.....	4
Features, Model and Cabinet Information .....	5



## **On-Screen Features**

### **PICTURE MENU**

- ◇ Adjusting Color, Brightness, Sharpness, Tint, Picture, and Color Temperature Controls ..6
- ◇ Using Clearview and Video Enhance Controls...7
- ◇ Adjusting the TV's Convergence Control .....
- ◇ Using the Flesh Correction Control .....

### **FEATURES MENU**

- ◇ Using the Analog Format Screen Control.....10
- ◇ Setting the TV for Closed Captioning.....11
- ◇ Setting the TV for Cable or Antenna Signals....12
- ◇ Adding Channels in Memory (Automatically) .13
- ◇ Adding Channels in Memory (Manually) .....
- ◇ Setting the TV Clock.....15
- ◇ Using the Sleep Timer Control .....
- ◇ Adjusting the Channel Display Control.....17
- ◇ Using the Time/Channel Reminder Control.....18
- ◇ Using Parental Control/Content Advisory:
  - Code Setup/Blocking Channels.....19-20
  - Content Advisory - Movie Ratings .....
  - Parental Guidelines.....23
  - Blocking Options/Review Settings.....24
- ◇ Using the Channel Label Control.....25
- ◇ Using the Language Selection Control.....26

### **SOUND MENU**

- ◇ Adjusting Bass, Treble, and Balance Sound Controls.....27
- ◇ Setting the Bass Boost Control .....
- ◇ Setting the TV for Stereo and SAP Programs ..28
- ◇ Using the Incredible Surround Control.....29
- ◇ Using the Volume Display Control.....29
- ◇ Using the TV Speaker On/Off Control with the Audio Output jacks .....
- ◇ Surround Sound Speaker Connections and Variable Audio Output Control .....
- ◇ Optional Surround Sound Connections .....
- ◇ Using the TV's Audio/Video Input and Output Jacks .....



## **Monitor (HD) Control Operation**

Connection of VGA and High Definition (HD) Component Video Equipment .....	38
Adjusting of Monitor Display Controls .....	39



## **Remote Control Operation**

Setting the Auto Picture Control.....	40-41
Using the Auto Sound Control.....	42
Using the Auto Surf Control.....	43



## **Picture-In-Picture (PIP)**

How to Use PIP (Connections) .....	44-45
How to Use PIP with the TV Remote.....	46
Selecting the Picture Source for PIP .....	47
Adjusting PIP Color, Tint, and Size .....	48
More PIP Connections (Cable Converter) .....	49



## **General Information**

Tips if Something Isn't Working .....	50
Glossary of TV Terms .....	51
Index .....	52
Warranty .....	53

## **SET-UP AND QUICK USE GUIDE**

Use the simple Set-Up Guide (supplied with your TV information packet) for details on:

- Antenna Hook-ups
- First Time Set-Up (Automatic Settings)
- Basic TV and Remote Control Operation
- On-Screen Menu Use



**NOTE:** The universal learn remote supplied with this HD PTV features a LCD window display set for a variety of accessory product functions. Due to the amount of optional components available within the remote's Device Reference and Learn Code Lists, please refer to the separate full-use Remote Control Owner's Manual for complete details on its use and operation.



**First Time Set Up** - automatically sets the TV for local channels, the correct picture signal (antenna or cable), and assists in the setting of TV's Guide Plus+ feature.

**Infrared Remote Control** - operates your TV set and a variety of wireless remote control VCRs, Cable TV Converters, and other accessory equipment.

**Standard TV broadcast (VHF/UHF) or Cable TV (CATV)** channel capability as well as advanced connectivity for high definition video and VGA.

**Closed Captioning** - allows the viewer to read TV program dialogue or voice conversations as on-screen text.

**Automatic Programming of channels** - for quick and easy selection of favorite stations available in your area.

**Picture-In-Picture (PIP)** - can show a TV program and the direct video output from an accessory (VCR, etc.) onto the TV screen at the same time.

**Parental Control for "Censoring"** - this feature can block out channels to keep children from watching undesirable programming. Parental Guideline and Movie Rating settings can also be used as part of the new Content Advisory Data system available with TV programming.

**Stereo TV** - with a built-in audio amplifier and a twin speaker system, reception of TV programs in both broadcast stereo sound or (SAP) bilingual broadcast are available.

**Twin Antenna (A/B) Inputs** - for easy displaying of two separate signal sources on the TV. An A/B button on the remote control switches the TV's Main screen between the two Antenna (A & B) Input options.

**Audio/Video Jacks** - for direct connections with VCRs (and other accessories) for quality TV picture and sound playback. Component Video Input connectors are also available for high fidelity color and picture resolution when using digital video source material, such as DVD.

**Surround Sound** - this TV set contains external; audio speaker connections for a more dynamic sound effect capable within the today's Home Cinema environment.

**Sleep-Timer** - automatically turns the TV OFF at preset time intervals.

**Smart/Auto Button** - for the control of TV Sound and Picture levels. Use the Smart/Auto Button on the remote to quickly select various audio modes matched to specific types of TV programming; to select video level adjustments for a variety of program sources; and to make quick one button channel selection of up to 10 of your favorite channels.

**High Definition Digital** - Projection Television capable of 1500x1080i interlaced imaging for superior resolution and performance. Line doubling circuitry and video processing technology able to output progressive scan material with clean, stable widescreen images. Triple lens system matched to first surface mirror and fine pitched lenticular screen methods which amounts to an incredible 1,620,000 pixels of display capability. High Definition Component and RGB Inputs are available as well for Y, Pb, Pr; horizontal/vertical sync, and RGB/VGA monitor input operation modes.

**Automatic Phosphor Aging Compensation (APAC)** - Automatic incremental shifting of TV screen elements to prevent any onscreen image outline retention or "screen burn" problems.

**GUIDE Plus+®** - Electronic TV Program guide which provides for daily television channel listings, descriptions of program content, sorting of shows by subject themes, and a variety of other VCR programming options. (See your separate GUIDE Plus+® Owner's Manual for further details.)

Because of continuous product improvements, the information mentioned in the documents accompanying your product are subject to change without notice.

As you unpack your TV please note that the following items have been included with your set:

- Owner's Manual
  - Safety Tip Information
  - Factory Service Center Locations
- Warranty Registration Card
- Remote Control Transmitter
- Batteries for Remote Control Use

Refer to the back of this manual for instructions on the cleaning and care of the TV.

## End-of-Life disposal

Your new projection television and its packaging contain materials that can be recycled and reused. Specialized companies can recycle your product to increase the amount of reusable materials and minimize the amounts which need to be properly disposed.

Your product also uses batteries which should not be thrown away when depleted, but should be handed in and disposed of as small chemical waste.

Please find out about the local regulations on how to dispose of your old television, batteries, and packaging materials whenever you replace existing equipment.

# PICTURE MENU CONTROL ADJUSTMENTS

## COLOR, BRIGHTNESS, SHARPNESS, TINT, PICTURE

To adjust your TV color and picture controls, select a TV channel and follow the steps shown below:

### (BEGIN)

- 1 Select **BRIGHTNESS, PICTURE, COLOR, TINT, or SHARPNESS** picture control.

With the PICTURE MENU on screen, move the RED highlight with the outer OK arrow buttons. Then press the center OK button to select the feature.

- 2 Press the **OK arrow** buttons to adjust the selected control.

- 3 Press the **STATUS** button to clear the screen.



## SMART HELP



Remember. When the bar scale is centered, control settings are at normal mid-range levels.

**BRIGHTNESS** Press (-) or (+) until dark parts of the picture show good detail.

**PICTURE** Press (-) or (+) until whitest parts of the picture are as bright as you prefer.

**COLOR** Press (-) or (+) to add or eliminate color.

**TINT** Press (-) or (+) to obtain natural skin tones. (Also see Flesh Correction on page 9 for more information).

**SHARPNESS** Press (-) or (+) to improve detail in the picture.

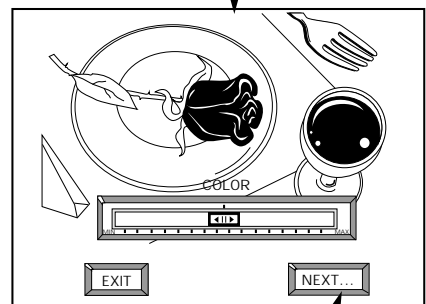
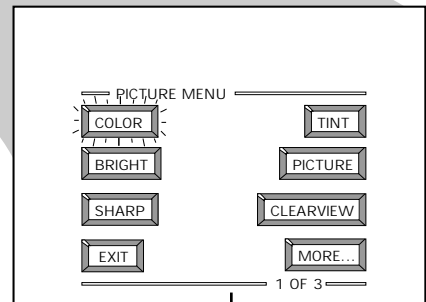
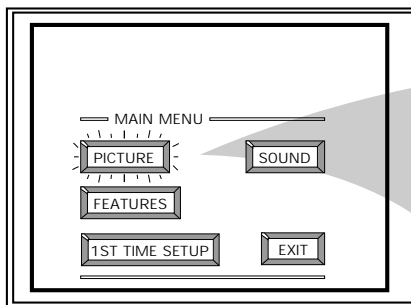

Select and then press MENU (M) button to view additional controls grouped under same feature heading. For Example: Tint, Brightness, Picture, etc.

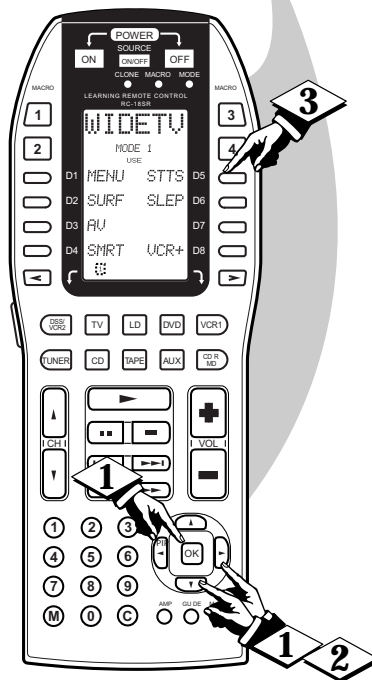

Note: A Color Temperature control is also available to set the level or degree of color intensity (especially on white picture screen elements). For example, use the Color Temperature (Picture Menu 3 of 3) for the following settings:  
**COOL** – makes whites, bluish  
**NORMAL** – keeps whites, white.  
**WARM** – makes whites, reddish.

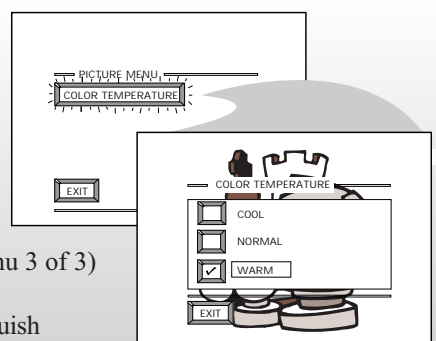

# PICTURE MENU CONTROLS (CONTINUED)

## CLEARVIEW

*Clearview is a sharpness feature which smoothes out background snow (or picture noise) without losing picture image detail or crispness.*

### BEGIN

**1** Select CLEARVIEW control.

With the PICTURE MENU on screen, move the RED highlight with the outer OK arrow buttons. Then press the center OK button to select the feature.

**2** Press the outer OK arrow buttons to move the RED highlight. Press the center OK button to select (✓) the ENHANCED mode.

**3** Press the STATUS button to clear the screen.

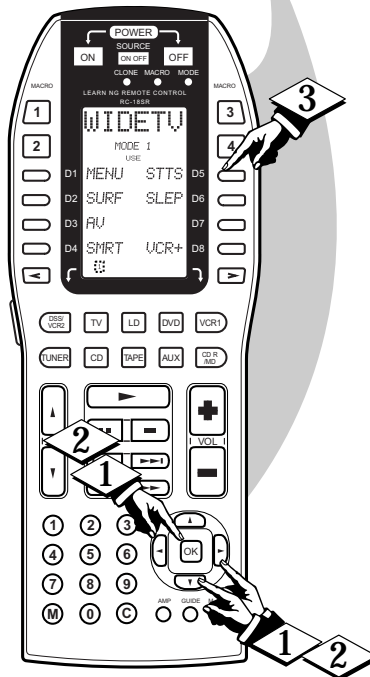
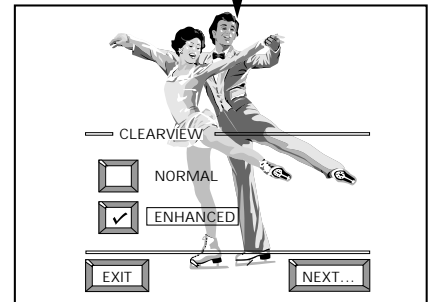
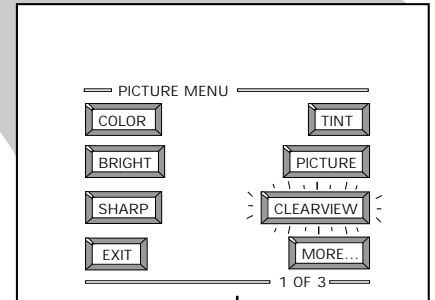
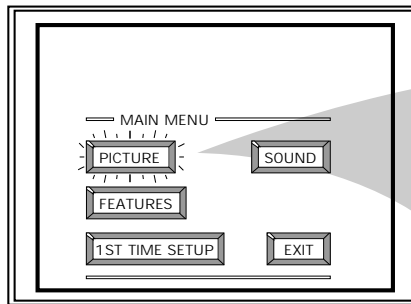

Note: An additional Picture Menu "VIDEO ENHANCEMENT" control (similar in function and use as the Sharpness control) is also available to further improve picture intensity and detail, particularly for the playback of DVD player source material. Selection and adjustment of the Video Enhancement control (Picture Menu 2 of 3) is the same as with other Color and Picture Menu control options.

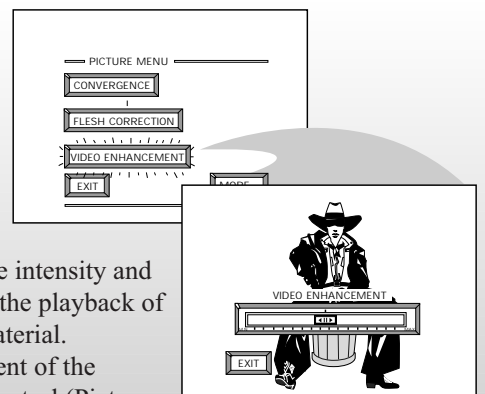

# PICTURE MENU CONTROLS (CONTINUED)

## RED/BLUE CONVERGENCE

Convergence is the correct lining up of the red and blue light paths on the TV screen.

**NOTE:** If no color fringing (see Smart Help) shows, then no Convergence adjustments are necessary for your TV.

### BEGIN

- 1 Select **CONVERGENCE** control.

With PICTURE MENU (2 of 3) on screen, move the RED highlight with the outer OK arrow buttons. Then press the center OK button to select the feature.

- 2 If there is **RED or BLUE** color fringing (see note below) on your TV, press the outer OK arrow buttons to move the highlight. Press the center OK button to select the Align Red or Align Blue Convergence control.

- 3 Press the **OK arrow buttons** to move the red or blue cross directly over the white cross on the TV screen.

The red or blue cross is properly adjusted when it is completely merged with the white cross. (No color appears around the edge of the white cross).

- 4 Press the **STATUS** button to clear the screen when convergence adjustments are complete.



## SMART HELP



Remember. Convergence has been set at the factory for best viewing, but if one or more of the (red or blue) colors appear around the edges of objects (color fringing) follow the steps given in this section.

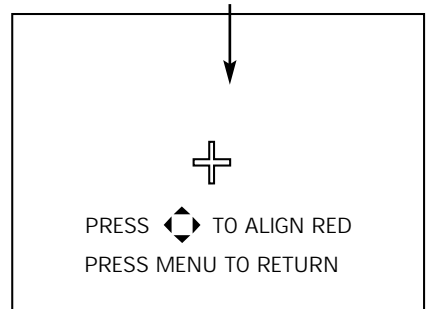
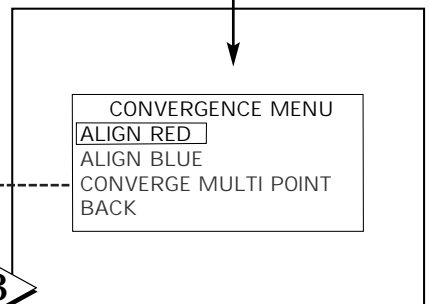
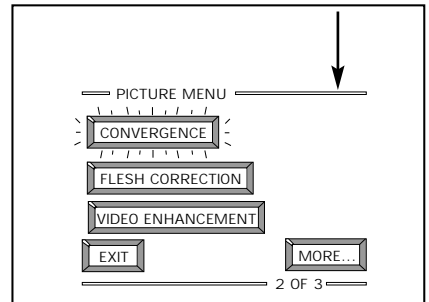
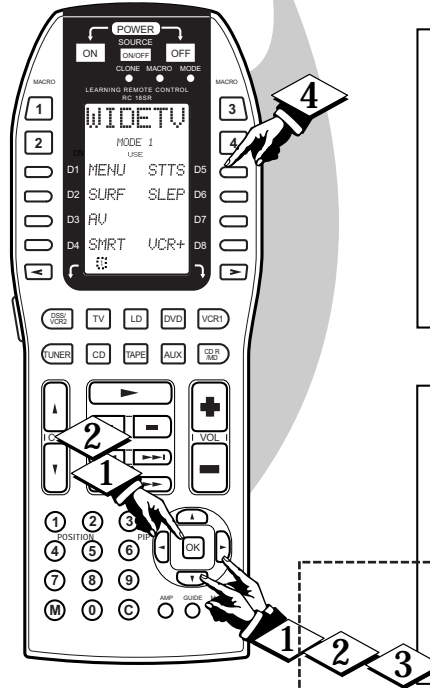
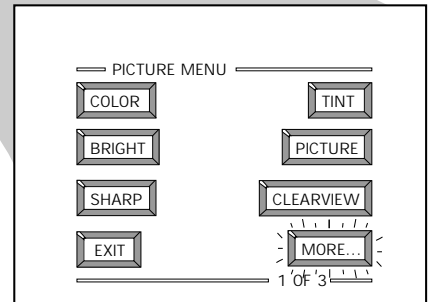
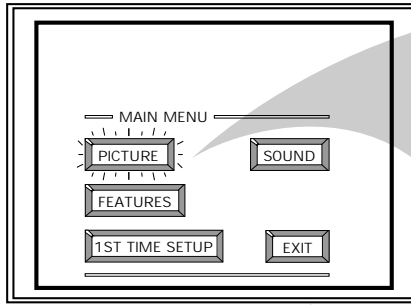

**NOTE:** Adjustments for "Multi Point" on screen color fringing can also be made as part of the TV's Convergence control system. Follow the TV's on screen menu directions to select individual screen areas that can be readjusted and set for varying red/blue color fringing conditions. These multi point settings can then be "Saved" for memory for the specific areas of the TV screen (or Factory Settings for convergence can be recalled and put back into place for use).

**CONVERGENCE MULTI POINT**

CONVERGE RED POINTS  
CONVERGE BLUE POINTS  
RESTORE FACTORY SETTINGS  
SAVE ADJUSTMENTS  
BACK

**MULTI-POINT CONVERGENCE**

CONVERGE RED POINTS  
USE [arrow] TO ADJUST  
DIGIT 2 4 6 8 TO MOVE CURSOR  
PRESS MENU TO RETURN  
PRESS MENU NOW TO CON



# PICTURE MENU CONTROLS (CONTINUED)

## FLESH CORRECTION

Use the *Flesh Correction* control to keep skin tone hues (or facial tint) from varying from TV channel to TV channel.

### BEGIN

- 1 Select **FLESH CORRECTION** control.

With PICTURE MENU (2 of 3) on screen, move the RED highlight with the outer OK arrow buttons. Then press the center OK button to select the feature.

- 2 Press the **OK arrow buttons** to move the RED highlight. Press the center OK button to turn (✓) the FLESH CORRECTION control ON.

- 3 Press the **STATUS** button to clear the screen.

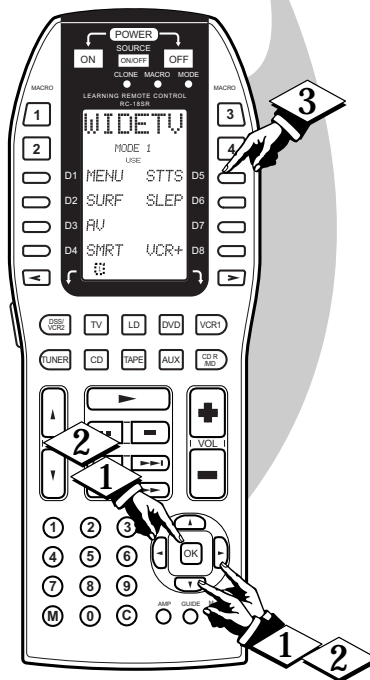
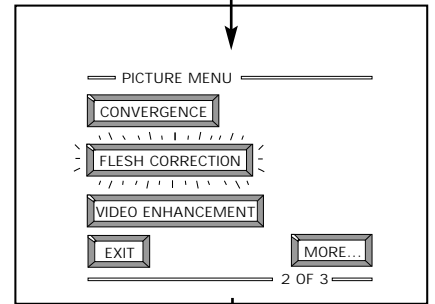
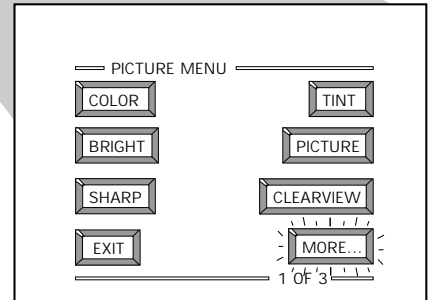
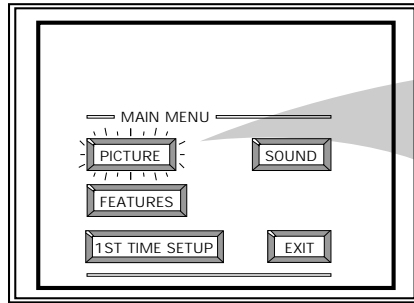

# FEATURE MENU CONTROL ADJUSTMENTS

## ANALOG FORMAT

Your TV is able to deliver lifelike, widescreen picture (or "home cinema" experience) that is promised with High Definition TV viewing. The Analog Format control can be used to expand conventional 4:3 aspect ratio (width to height) broadcasts in order to fit your TV's widescreen format; or to reset the screen to best match the current programming.

### BEGIN

- 1 Select ANALOG FORMAT control.

With the FEATURES MENU on screen, move the RED highlight with the outer OK arrow buttons. Then press the center OK button to select the feature.

- 2 Press the OK arrow buttons to move the RED highlight. Press the center OK button to select (✓) the desired screen aspect ratio or screen display control.

- 3 Press the STATUS button to clear the screen.

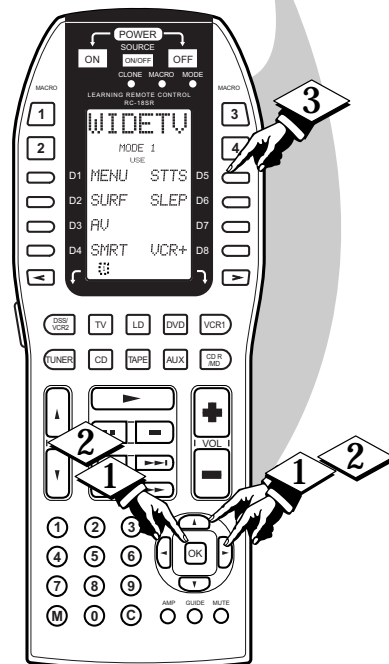
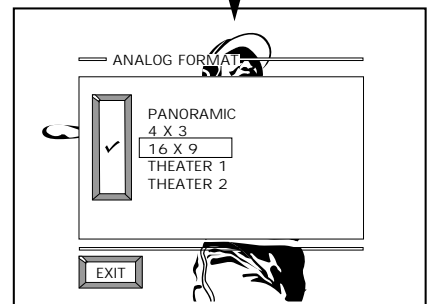
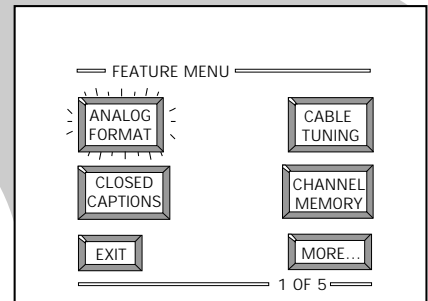
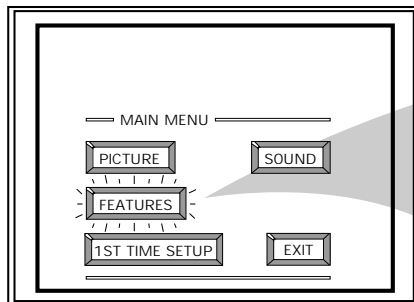

## SMART HELP



Note: In the past the relationship between a TV screen's width to height, or aspect ratio, has historically been 33% wider than the picture screen height (or a 4:3 aspect ratio). The widescreen format of your TV screen is nearly 80% greater than its measure height (which accounts for a 16:9 aspect ratio). The reason for the 16:9 aspect ratio screen is that it allows for the dramatic and lifelike viewing of original version movies and cinemas (similar to the type found in your local theaters). And the 16:9 aspect ratio widescreen is also a good visual match for how our eyes work in a horizontally oriented field of view and action plane.

Note: The LCD Display MODE 2 screen on the remote control can also be used to quickly select various aspect ratio screen control settings for TV viewing. Press the LCD screen direction (< >) buttons on the remote to select the WideTV Mode 2 display for use. Then press the correct (D) callout button to select the desired screen aspect ratio. Note: Not all of the MODE 2 LCD display settings may be available for use with your select model HD PTV.

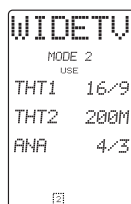

**Panoramic** - Conventional picture is expanded to fill the full 16:9 aspect ratio screen area. Most of the non-linear picture expansion is performed toward the outer edges so that correct proportions are retained in the center of the screen.



4 X 3



16 X 9



**4:3 (Standard)** - Conventional TV picture format shows on the screen. Black bar areas show on the side margins of the screen.

**16:9 (Expand)** - Full widescreen mode with linear expansion to view HD program broadcasts. Used for material originally produced in 16:9 format.

**Theater 1/2** - Expanded zoom modes with picture images increased in magnification. Designed for use with "letterbox" or cropped movie images such as found with Cinemascope or Cinerama type program material. Note: With the Theater modes there can be some loss of information at the edges as the picture expands to fill the screen.



# FEATURE MENU CONTROLS (CONTINUED)

## CLOSED CAPTION

*Closed Captioning (CC) allows you to read the voice content of television programs on the TV screen. Designed to help the hearing impaired this feature uses on screen "text boxes" to show dialogue and conversations while the TV program is in progress.*

### BEGIN

#### 1 Select CLOSED CAPTIONING control.

With the FEATURES MENU on screen, move the RED highlight with the outer OK arrow buttons. Then press the center OK button to select the feature.

#### 2 Press the OK arrow buttons to move the RED highlight. Press the center OK button to select (✓) the desired Closed Caption mode - For Example: "ALWAYS ON" and "CAPTION 1".

**CAPTION 1, 2, 3, 4:** dialogue (and descriptions) for the action on the captioned TV program shows on-screen. (See Important Note on this page.)

**TEXT 1, 2, 3, 4:** often used for channel guide, schedules, or bulletin board information for CC programs.

#### 3 After making your Caption mode selection, press the STATUS button to clear the TV screen. The selected Closed Caption mode will be active.

**To cancel,** set the Closed Captioned feature to OFF when finished.



## SMART HELP

Remember. Broadcast stations will often use spelling abbreviations, symbols, dropouts and other grammatical shortcuts in order to keep pace with the on-screen action. These type factors vary upon the source of the captioned text material and do not indicate a need for service on the part of the TV.

**NOTE: Not all TV programs and product commercials** are made for broadcast with Closed Caption (CC) information included. Neither are all Closed Caption modes (CAPTION 1-4; or TEXT 1-4) necessarily being used by a broadcast station during the transmission of a closed caption program. Usually "CAPTION 1" is the most used mode to view captioned material. Refer to your area's TV program listings for the stations and times of Closed Caption shows.

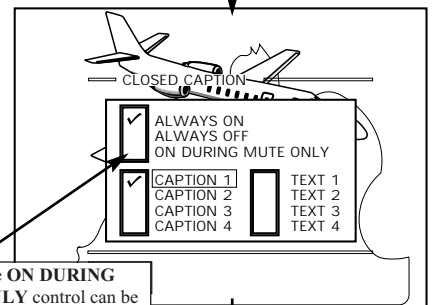
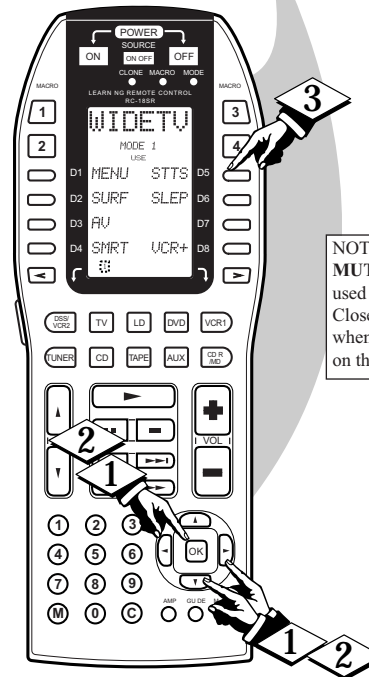
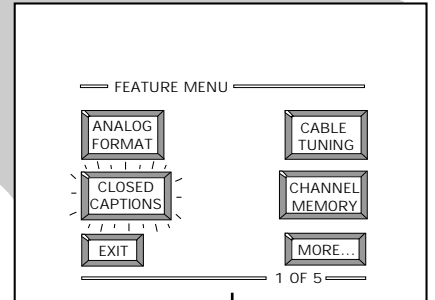
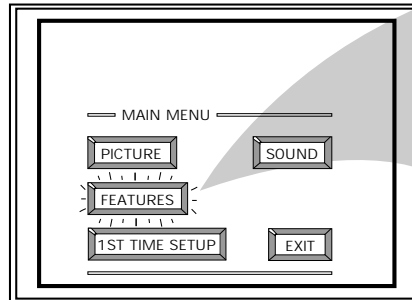

**NOTE: The ON DURING MUTE ONLY control** can be used to set the TV to turn the Closed Caption mode "ON" whenever the MUTE button on the remote is pressed.



CAPTION 1 mode  
Example Screen Display

Closed Caption information will usually appear in black and white (although some broadcasters or networks may occasionally use color to highlight or draw attention to certain areas.)

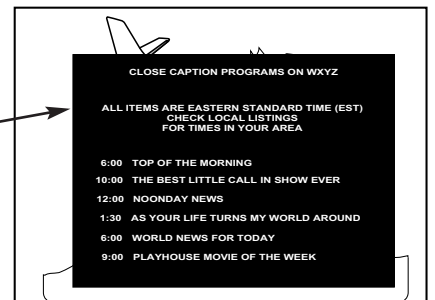

FULL SCREEN TEXT  
will block TV screen from viewing

# FEATURE MENU CONTROLS (CONTINUED)

## CABLE TUNING

You need to make sure the TV is set to pick up either Cable TV or Antenna signals. In other words, the TV needs to know if you connected a Cable TV signal or a normal antenna to its ANTENNA plug.

*NOTE: If you went through First Time Setup (in your Quick Use Guide), this task has already been completed for you.*

### (BEGIN)

- 1 Select **CABLE CHANNEL TUNING** control.

With the FEATURES MENU on screen, move the RED highlight with the outer OK arrow buttons. Then press the center OK button to select the feature.

- 2 Press the **OK arrow buttons** to move the RED highlight. Press the center OK button to select (✓) the desired mode - For Example: CABLE.

**CABLE-** If you **DO** have Cable TV connected to the TV. Channels 1-125 available.

**NORMAL-** If you have an Antenna connected to the TV. Channels 2-69 available.

- 3 Press the **STATUS** button to clear the screen.

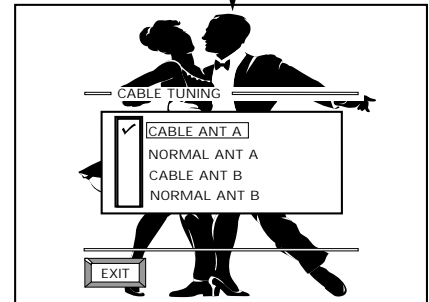
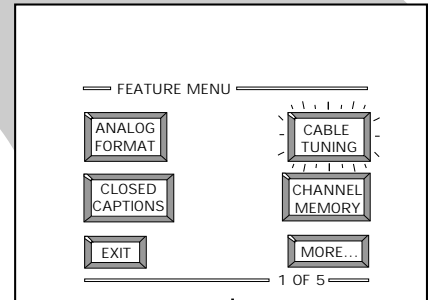
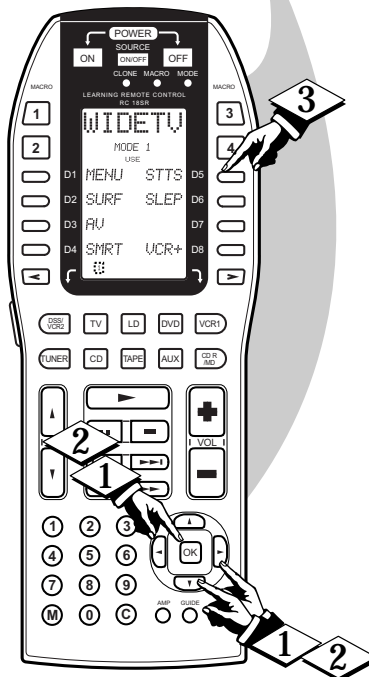
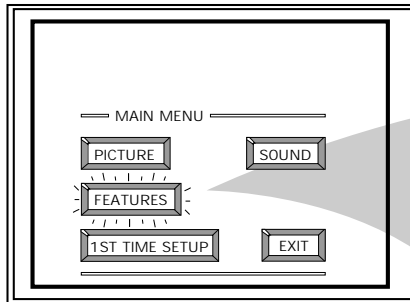

Note: Both ANT(enna) A and ANT B inputs on the rear of the TV can be set for the correct connected signal (either an Antenna or Cable TV source).

# FEATURE MENU CONTROLS (CONTINUED)

## CHANNEL MEMORY AUTO-PROGRAMMING

Your TV can automatically set itself for local area (or Cable TV) channels. This makes it easy for you to select only the TV stations in your area when the CHANNEL ▲▼ buttons are pressed.

NOTE: If you went through First Time Setup (in your Quick Use Guide), this task has already been completed for you.

### BEGIN

- 1 Select CHANNEL MEMORY (START AUTO-PROGRAMMING) control.

With the FEATURES MENU on screen, move the RED highlight with the outer OK arrow buttons. Then press the center OK button to select the feature.

- 2 Press the center OK button to turn AUTO-PROGRAMMING ON.

The TV shows which channel numbers are "SAVED" (✓) as they are added into memory.

"Auto-programming CHANNEL MEMORY is finished" shows when the TV is through adding channels.

- 3 Press the STATUS button to clear the screen.



## SMART HELP



Try it out. Press the CHANNEL ▲▼ buttons and see which channels you can select.

Remember, an Antenna or Cable TV signal must first be connected to your TV so that channels can be saved.

If you want to delete any unwanted channels from the TV's memory, see "ADD/DELETE CHANNELS" on the next page.

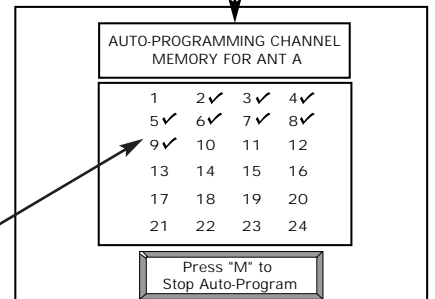
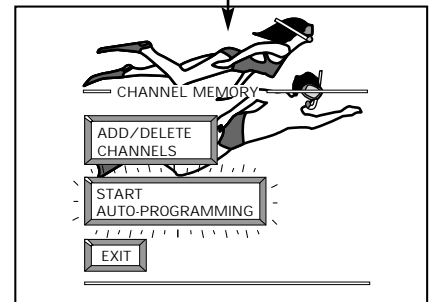
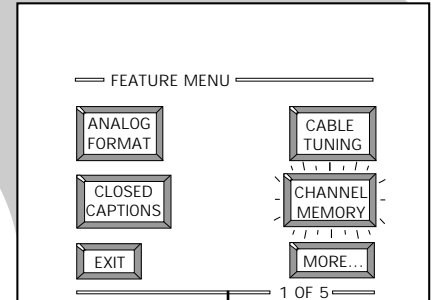
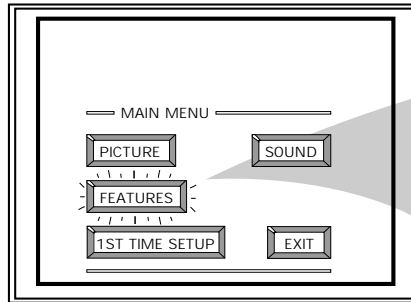

✓ Channel Numbers are Saved in Memory

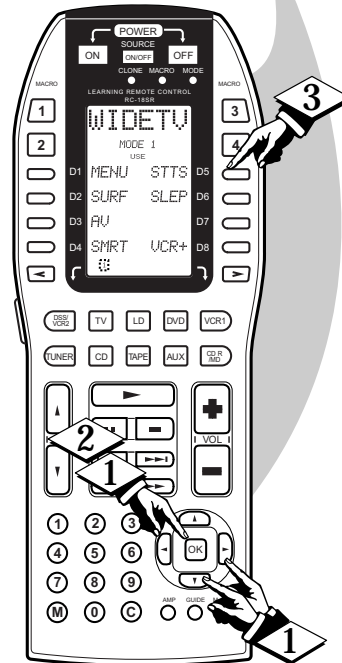

# FEATURE MENU CONTROLS (CONTINUED)

## ADD/DELETE CHANNELS

*Auto Programming (see previous page) adds all the channels it can find (on your Antenna or Cable TV system) into the TV's memory. Add/Delete Channels makes it easy for you to add other channels, or drop unwanted channels, from the list of channels in the TV's memory.*

### BEGIN

- 1 Select **CHANNEL MEMORY (ADD/DELETE CHANNELS)** control.

With the **FEATURES** MENU on screen, move the **RED** highlight with the outer OK arrow buttons. Then press the center OK button to select the feature.

- 2 Press the **CHANNEL ▲▼** or **number** buttons to select the channel you want to add or delete.

- 3 Press the **outer OK arrow button** (on the Right) to **ADD** the channel into the TV's memory.

Press the outer OK arrow button (on the Left) to **DELETE** the channel from memory.

Repeat steps 2 and 3 for each channel you wish to add or delete.

- 4 Press the **STATUS** button to clear the screen when through.

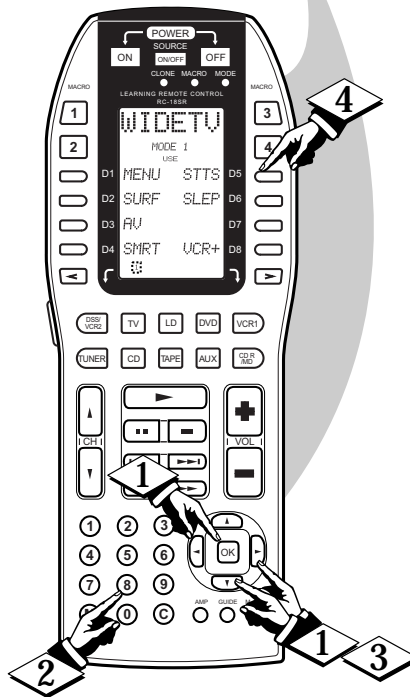
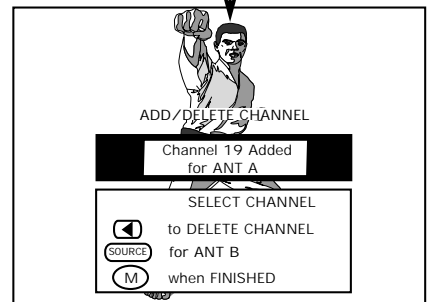
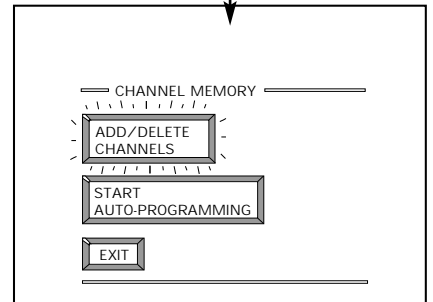
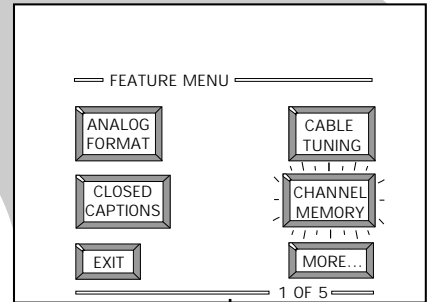
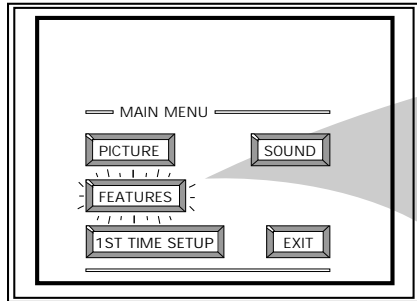

## SMART HELP



Remember. A separate **ADD/DELETE CHANNEL** memory may also be created for the **ANT(enna) B** Input on the rear of the set (if an Antenna or Cable TV signal has been connected). Press the **"SOURCE"** button on the remote, while in the **ADD/DELETE CHANNEL** mode, to switch between the **ANT A** and **ANT B** channel memory lists. Then follow steps 2 and 3 as shown to the left to add or delete the desired channels.

# FEATURE MENU CONTROLS (CONTINUED)

## SET CLOCK

Your TV comes with an on screen clock. During normal operation the clock appears on the screen with every channel change (and when the STATUS button is pressed).

### (BEGIN)

- 1 Select SET CLOCK control.  
With the FEATURES MENU (2 of 5) on screen, move the RED highlight with the outer OK arrow buttons. Then press the center OK button to select the feature.
- 2 Press the remote's number buttons to set the time clock.
- 3 Press the STATUS button to set the clock in operation and clear the screen.



### SMART HELP

Remember, be sure to press "0" first and then the hour number for single digit entries.

The remote's OK arrow buttons can also be used to set the hours, minutes and AM/PM portions of the clock.

TV Clock settings may be lost when the TV is unplugged (or AC power to the set is interrupted).

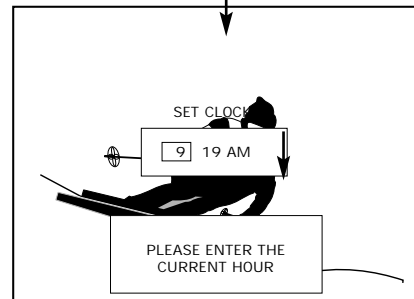
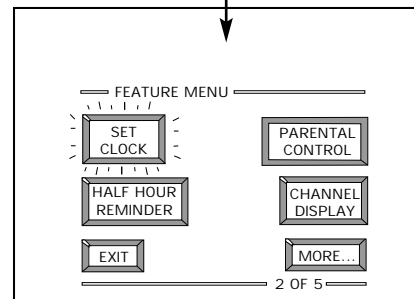
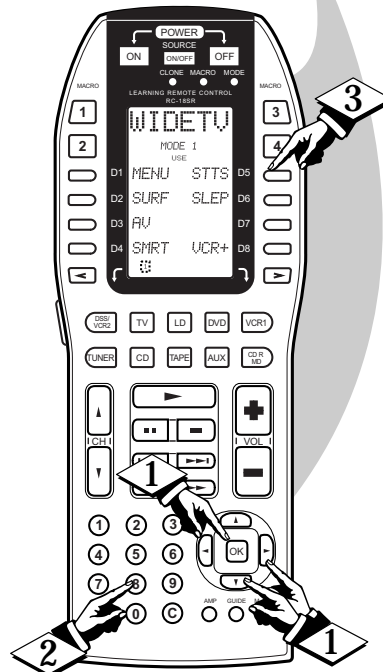
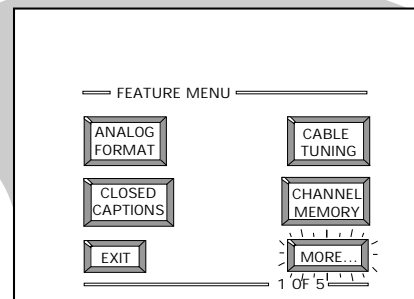
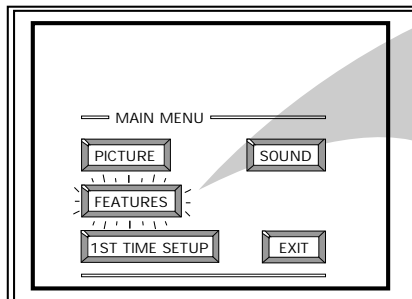

## FEATURE MENU CONTROLS (CONTINUED)

### SLEEP TIMER

*Have you ever fallen asleep in front of the TV only to have it wake you up at two in the morning with a test pattern screeching in your ears? Well, your TV can save you all that trouble by automatically turning itself off.*

#### BEGIN

**1** Press the **SLEEP** button on the remote control (LCD Display Mode 1 screen - D6 button).

**2** Press the **SLEEP** button repeatedly to pick the amount of time (15 minutes to 2 hours ahead) before the TV will turn itself off.

**3** Press the **STATUS** button to clear the screen after you have set the time for the TV to turn off.

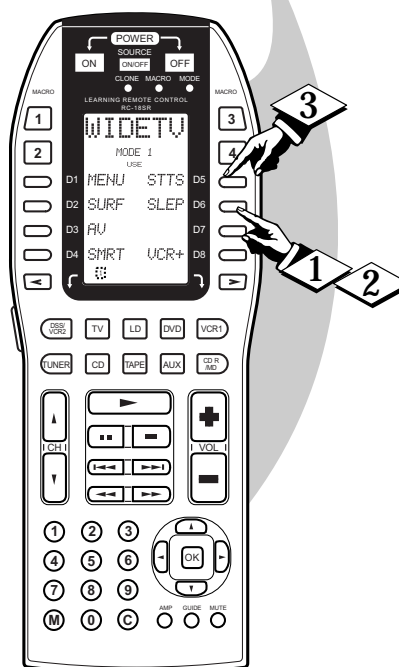
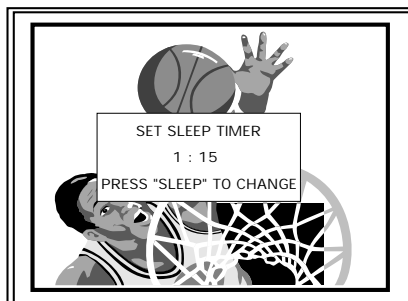

### SMART HELP



Remember, to see how many minutes are left before the TV shuts itself off, reselect the **SLEEP TIMER** control screen.

To stop a **SLEEP TIMER** setting, reset the timer back to **OFF**.

(Turning the TV off and on, or pressing a button during the last minute of a timer setting, will also cancel a setting.)

A few seconds before the TV is to shut off a message will come on the screen telling you *GOOD NIGHT*.



# FEATURE MENU CONTROLS (CONTINUED)

## CHANNEL DISPLAY

With the Channel Display control you can change the size and location of the on screen channel and clock information.

**BEGIN**

- 1 Select CHANNEL DISPLAY control.

With the FEATURES MENU (2 of 5) on screen, move the RED highlight with the outer OK arrow buttons. Then press the center OK button to select the feature.

- 2 Press the OK arrow and center OK buttons to highlight and select (✓) the LARGE or SMALL display control.

- 3 Press the STATUS button to clear the screen.



## SMART HELP

Try it out. Press the CHANNEL ▲▼ buttons and you should see the Display Size you selected.

Remember. The SMALL SIZE display shows only the channel number, not the time (or clock).

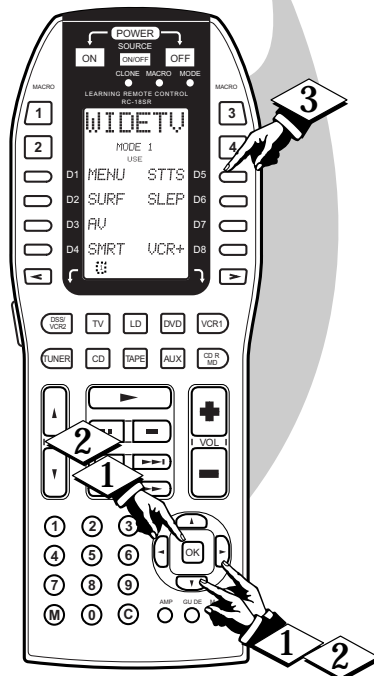
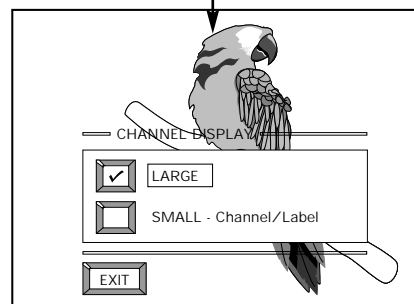
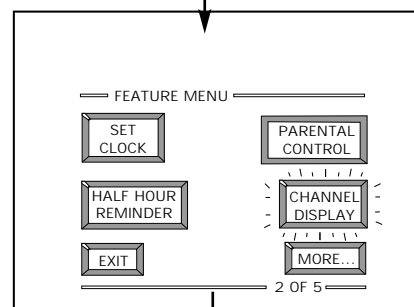
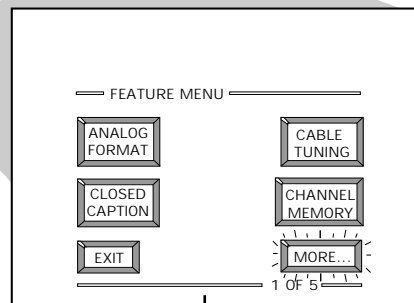
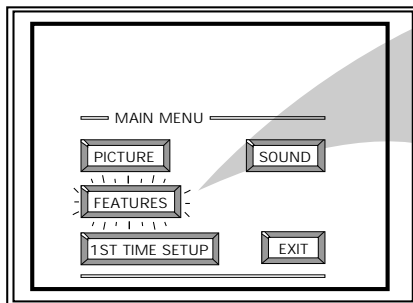

# FEATURE MENU CONTROLS (CONTINUED)

## HALF HOUR REMINDER

*With the Half Hour Reminder control the TV automatically shows you the current time and channel every thirty minutes.*

### BEGIN

#### 1 Select HALF HOUR REMINDER control.

With the FEATURES MENU (2 of 5) on screen, move the RED highlight with the outer OK arrow buttons. Then press the center OK button to select the feature.

#### 2 Press the OK arrow and center OK buttons to highlight and select (✓) the EVERY HALF HOUR item.

#### 3 Press the STATUS button to clear the screen.



### SMART HELP

Remember. The Time and Channel Reminders will show on the hour and the half-hour for about five seconds.

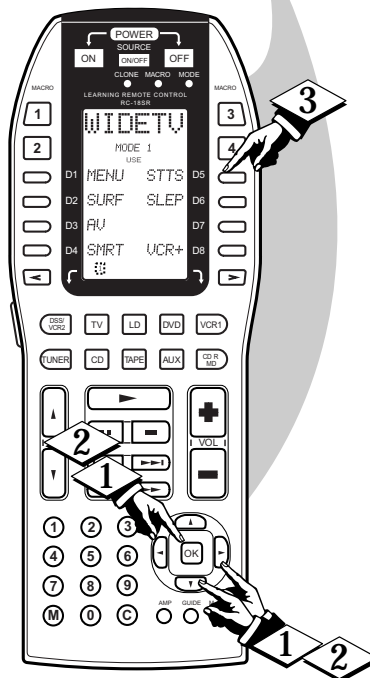
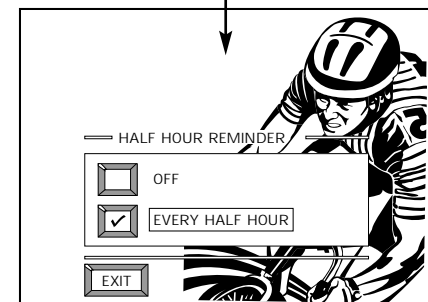
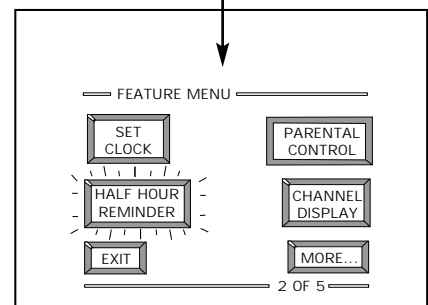
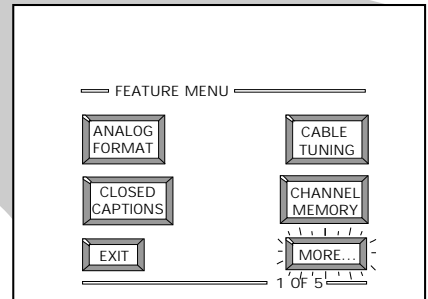
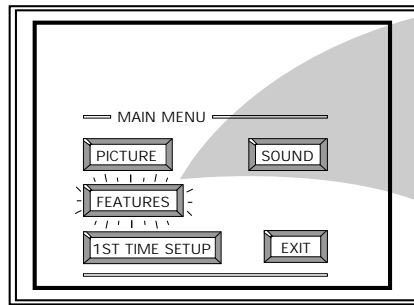

# FEATURE MENU CONTROLS (CONTINUED)

## PARENTAL CONTROL

### SETUP CODE NUMBER

*Parental Control allows parents to block out, or "censor", any channels they think children should not watch. A channel placed under Parental Control cannot be viewed until a correct access code is used to unlock the channel for viewing.*

*First let's set your Parental Code:*

#### **BEGIN**

#### **1** Select the PARENTAL CONTROL.

With the FEATURES MENU (3 of 5) on screen, move the RED highlight with the outer OK arrow buttons. Then press the center OK button to select the feature.

"CHANNEL BLOCKING" and "SETUP CODE" show on screen.

#### **2** Press the OK arrow and center OK buttons to highlight and select the SETUP CODE item.

#### **3** Press 0, 7, 1, 1 on the remote.

"XXXX" shows on the ACCESS CODE SETUP screen as you press the number buttons.

"INCORRECT ACCESS CODE - TRY AGAIN" will also show on the screen.

#### **4** Press 0, 7, 1, 1 on the remote again.

"Next Enter Your New Access Code" shows on the screen.

#### **5** Enter a new four digit number code using the remote.

"Access Code Changed" shows on the screen to let you know the new code has been set.

*Continue to the next page to find out how to "BLOCK" channels from viewing.*

NOTE: Your TV left the factory with the Parental Code set to "0000". If you are using your TV and the Parental Control for the first time, and don't want to SETUP a new Access code number, you can use the "0000" number to block channels see next page. The "0711" Parental Code (shown on this page) is given as a default or way to reset the Code when the current Access number is not known.

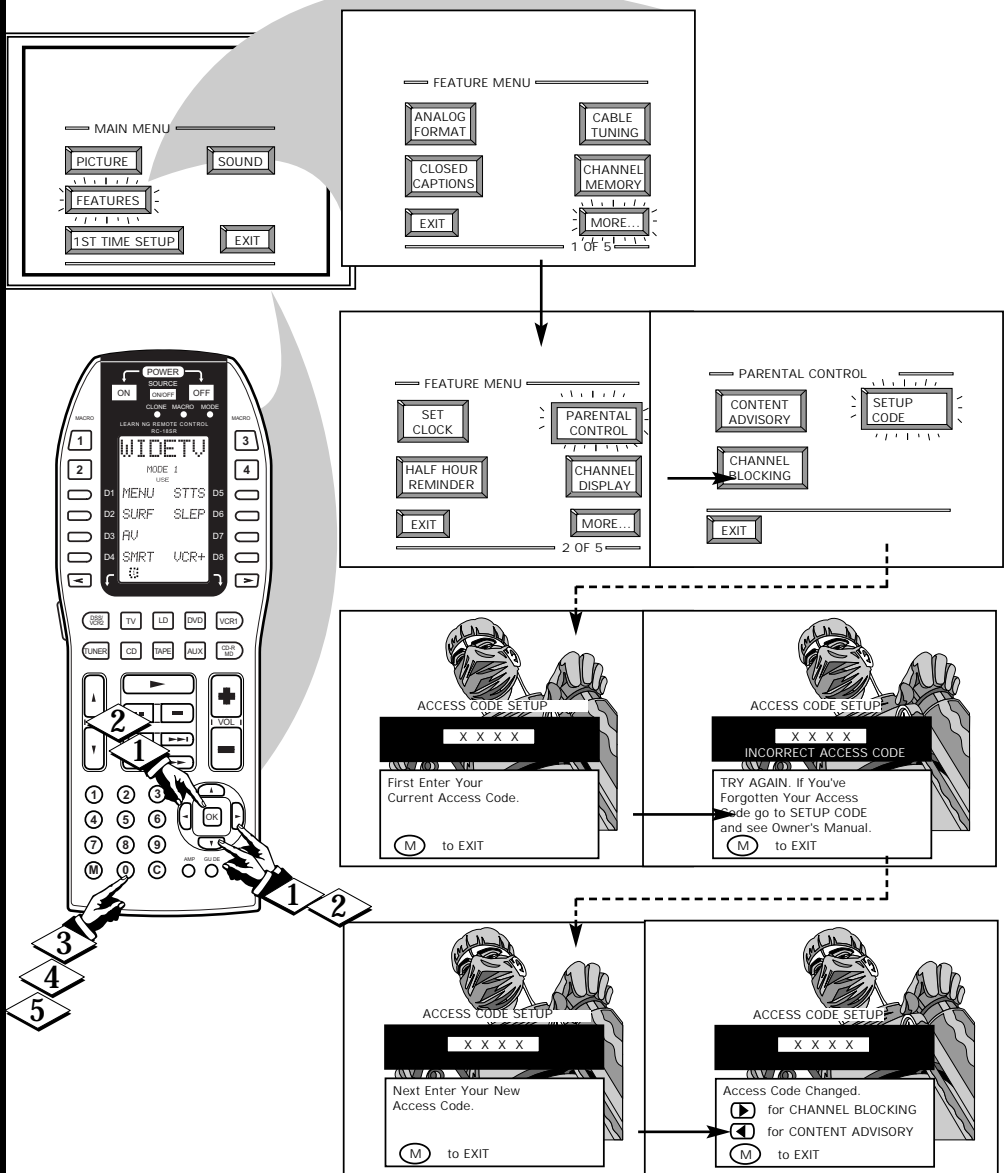

- Press outer OK arrow button (on the Right) to go on and start to "block" channels.
- Press outer OK arrow button (on the Left) to go to "Content Advisory" (or TV and Movie Ratings system of channel blocking).
- Press the center OK button to return to the Parental Control Menu screen.
- Press STATUS to clear the screen.

## SMART HELP



Parents - it isn't possible to unlock or defeat your Censor Code without changing to a new code number. So if your Code number changes, and you didn't change it yourself, then you will know that someone has altered the code and the blanked out channel has been viewed.

# FEATURE MENU CONTROLS (CONTINUED)

## PARENTAL CONTROL

### CHANNEL BLOCKING

After your personal Parental Code number has been set (see previous page), you are now ready to select the channels you want to block out or censor.

**BEGIN**

**1** Select the **BLOCK CHANNELS** control.

With the FEATURES MENU (3 of 5) on screen, move the RED highlight with the outer OK arrow buttons. Then press the center OK button to select the feature.

**2** Press the **OK** arrow and **center OK** buttons to highlight and select the **CHANNEL BLOCKING** item.

**3** Enter the correct **Parental Code** number.

**4** Press **Channel ▲▼** or **Channel Number** buttons to select the channel you want to block.

**5** Press the **outer OK** arrow button (on the right) to "BLOCK VIEWING" on the selected channel. Press the **outer OK** arrow button (on the left) to "ALLOW VIEWING" on a blocked channel. Repeat steps 3 and 4 for any other channels you wish to block out.

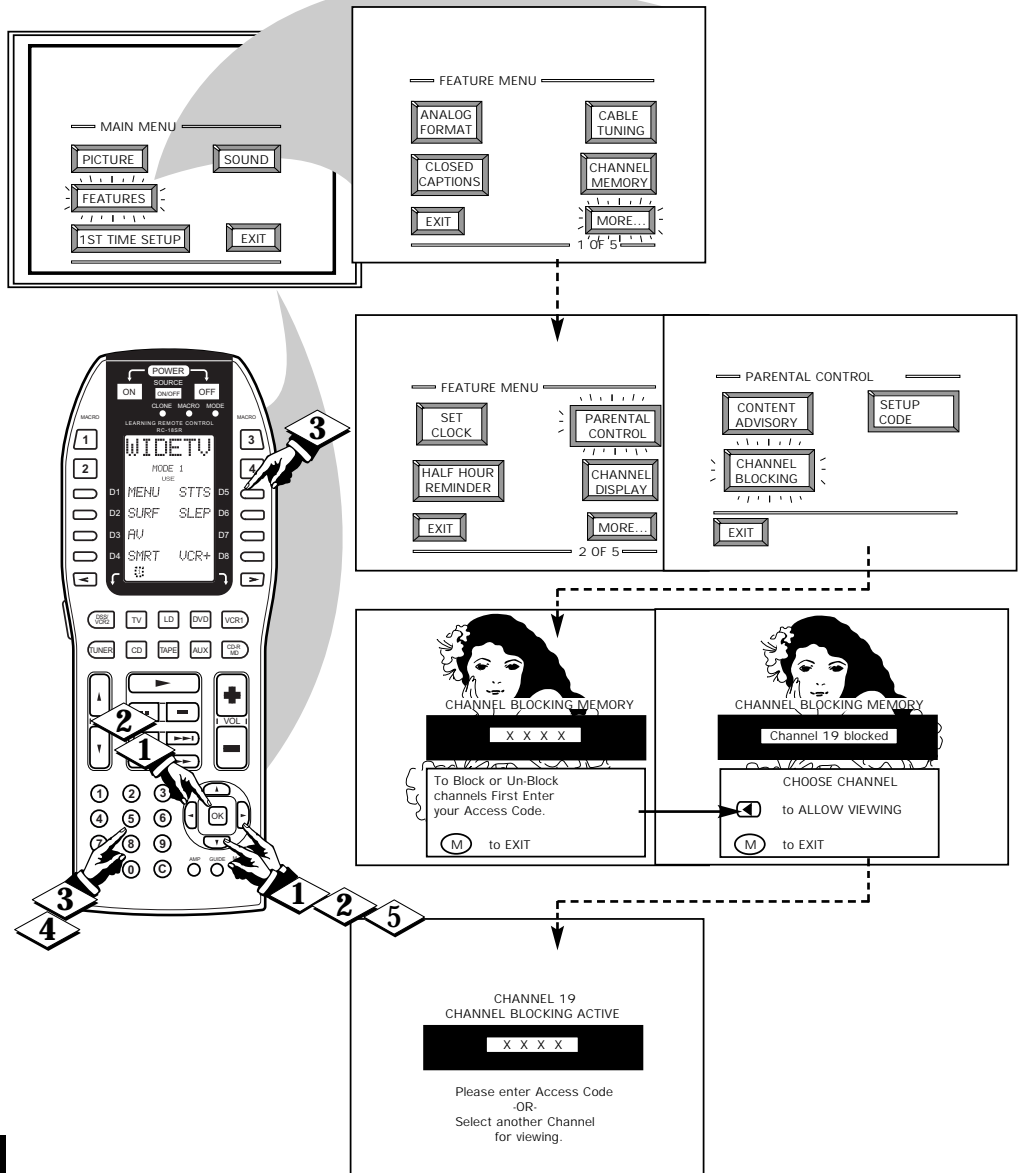

**BLOCKED CHANNEL SCREEN MESSAGE**  
(Appears when an attempt to select a blocked channel is made and Parental Control is ON.)

## SMART HELP



Remember, once set Parental Control blocks out the selected channel number on both the ANT A and ANT B channel rings. Also, to make TV viewing easier all channels (for both ANT A/B) will be unblocked, once the correct Parental Code number has been entered. When the TV is turned OFF and then back ON again, is when Parental Control is back in place for all blocked out channels.

# FEATURE MENU CONTROLS (CONTINUED)

## PARENTAL CONTROL CONTENT ADVISORY

Another new area available to parents for the censoring of program material is through the TV Guidelines and Movie Ratings system. Program Content Advisory data will soon be contained within the broadcast signals of received TV programs. When setup by the parent or viewer, the TV can respond to transmitted advisory data by blocking out or denying access to TV shows (based on whether the program meets or exceeds the limitations you select as viewable). The TV program can then only be viewed by entering the correct and current Parental Code Access number.

The Content Advisory system uses both "Movie Ratings" and a "Parental Guidelines" form of censoring. Refer to the following page sections for explanations on the different Rating system levels and their uses.

### (BEGIN)

#### 1 Select the CONTENT ADVISORY Menu option

With PARENTAL CONTROL Menu on screen, move the RED highlight with the outer OK arrow buttons. Then press the center OK button to select the feature.

A Parental Guideline/Movie Rating status screen will appear with a review of currently BLOCKED Content Advisory categories.

#### 2 Press the outer OK arrow button (on the right) to select the ENTER ACCESS CODE Menu item.

#### 3 Enter the correct Parental Code number (see note at the top of this page).

"CONTENT ADVISORY" Menu screen appears. Parental Guidelines, Movie Ratings and other blocking control items are ready for selection and use.



**Note:** Please remember that a valid and current Access Code number will be required in the setup and use of the TV's "Content Advisory" system. Review the previous **SETUP CODE** section on how to obtain a valid Parental Access Code number before attempting to make adjustments within the Movie Ratings and Parental Guidelines system.

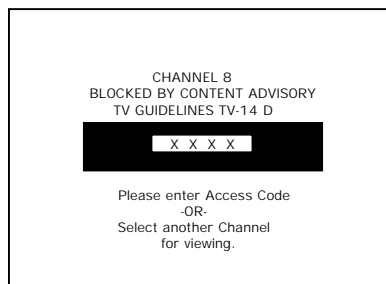
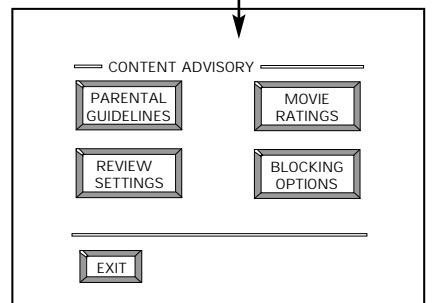
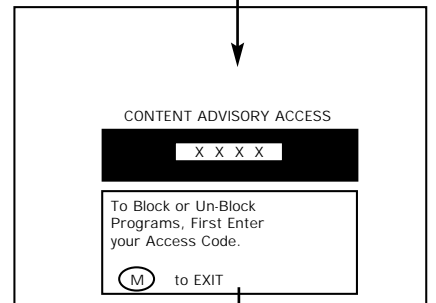
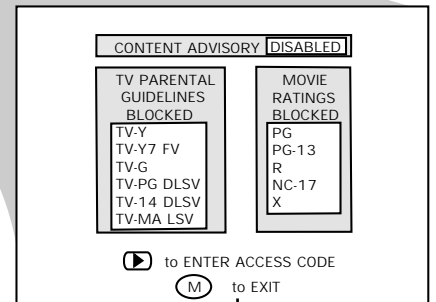
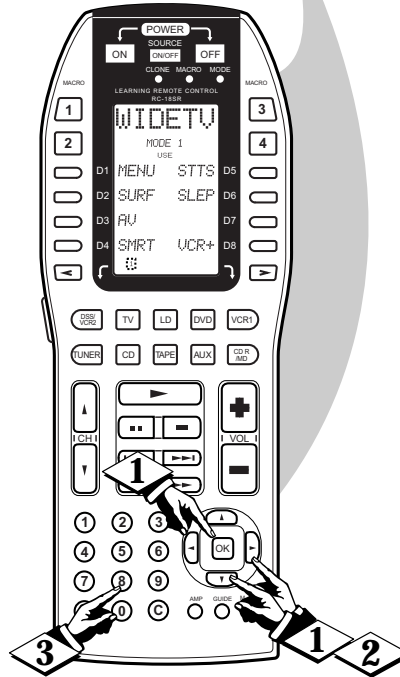
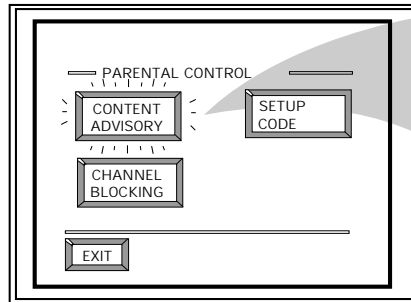

**NOTE:** In normal Content Advisory system operation the TV screen will display a message when programming is blocked by a Movie Rating, Parental Guideline, or Blocking Option control feature. Entering the correct ACCESS CODE number will unblock all the blocked Content Advisory Rated channels until the TV is turned Off. The blocked Advisory Ratings will be back in place when the TV is turned back On again.

# FEATURE MENU CONTROLS (CONTINUED)

## CONTENT ADVISORY MOVIE RATINGS

*Movie Ratings set viewing Access levels for TV programming according to current Motion Picture Association of America (MPAA) ratings. These ratings are similar to the categories used with the rated movies appearing in cinema theaters and with video rental material.*

### BEGIN

- 1 Select the **MOVIE RATINGS** Menu option.

With **CONTENT ADVISORY** Menu on screen, move the **RED** highlight with the outer **OK** arrow buttons. Then press the center **OK** button to select the feature.

- 2 Press the **OK** arrow and center **OK** buttons to highlight and select (✓) the desired **MOVIE BLOCKING** level.

When in operation a “Blocked - Movie Rating” TV screen appears when movies are received which include the same selected rating as the **Movie Blocking** setting(s). Only the correct **Access Code** number, entered by the viewer, will unblock or allow the viewing of a block rated program.

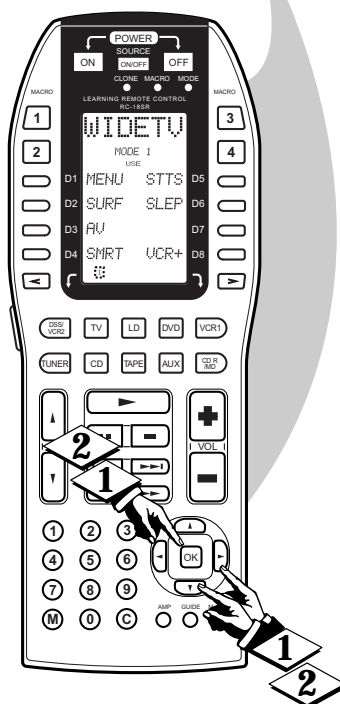
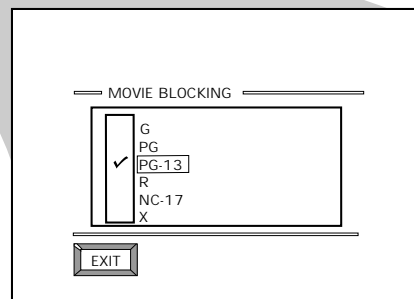
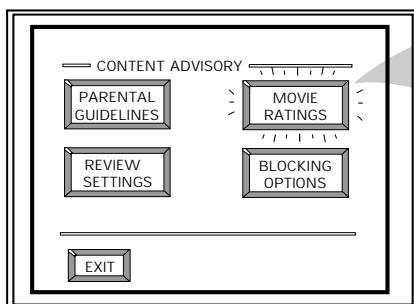

- **G - General Audience:** Most parents would find this program suitable for all ages. This type of programming contains little or no violence, no strong language, and little or no sexual dialogue or situations.
- **PG - Parental Guidance:** This programming contains material that parents may find unsuitable for younger children. It may contain one or more of the following: Moderate violence, some sexual situations, infrequent coarse language, or some suggestive dialogue.
- **PG-13:** This programming contains material that parents may find unsuitable for children under the age of 13. It contains one or more of the following: violence, sexual situations, coarse language, or suggestive dialogue.
- **R - Restricted:** This programming is specifically designed for adults. Anyone under the age of 17 should only view this programming with an accompanying parent or adult guardian. It contains one or more of the following: intense violence, intense sexual situations, strong coarse language, or intensely suggestive dialogue.
- **NC-17 - No one under 17 admitted:** This type of programming should be viewed by adults only. It contains graphic violence, explicit sex, or crude indecent language.
- **X - Mature audience only:** This type of programming contains one or more of the following: very graphic violence, very graphic and explicit or indecent sexual acts, very coarse and intensely suggestive language.

## SMART HELP



Note: When a **Movie Rating** is selected (✓) all higher level ratings are automatically blocked (although each individual **Movie Rating** can be manually selected and turned On or Off as desired). Programs with lower than the selected rating level are allowed for viewing or unblocked.

# FEATURE MENU CONTROLS (CONTINUED)



## CONTENT ADVISORY PARENTAL GUIDELINES

*Parental Guidelines can be even more defined and specific in the degree and extent of material parents may allow for TV program viewing. Sub settings for Language, Violence, and other blocking factors can be manually switched On or Off for use within the major Parental Guideline categories (TV Y7, TV PG, etc.).*

**(BEGIN)**

**1** Select the **PARENTAL GUIDELINES** Menu option.

With **CONTENT ADVISORY** Menu on screen, move the **RED** highlight with the outer **OK** arrow buttons. Then press the center **OK** button to select the feature.

**2** Press the **OK** arrow (Left and Right side) buttons to highlight and select the desired **PARENTAL GUIDELINE** rating level (TV-Y, TV-Y7, etc.).

**3** Press the **OK** arrow and center **OK** buttons to Block (✓) the selected Parental Guideline category (or to set other individual blocking feature items available within that Guideline category (L, V, S, D, etc.) as desired).

Note: Selecting "ALWAYS BLOCKED" (or individually adjusting the L, V, S, D settings) for any one rating will set all other higher level ratings to be automatically blocked as well.



## SMART HELP



The TV-Y7; TV-PG; TV-14; and TV-MA guidelines also include customized settings for various additional items such as V (violence), S (sexual situations), L (coarse language), D (suggestive dialogue), and FV (fantasy violence). These additional settings are category specific and can be individually selected for use as desired.

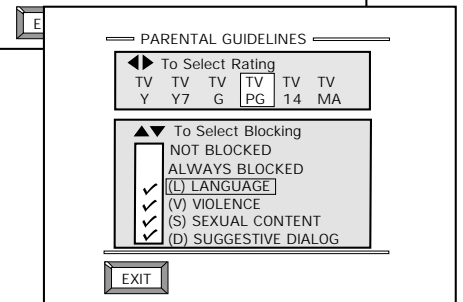
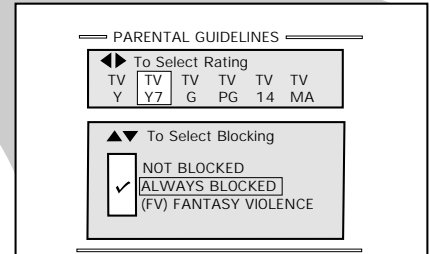
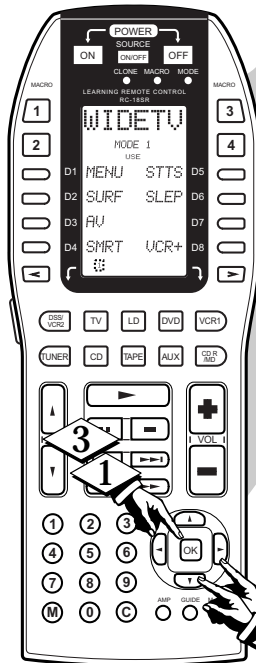
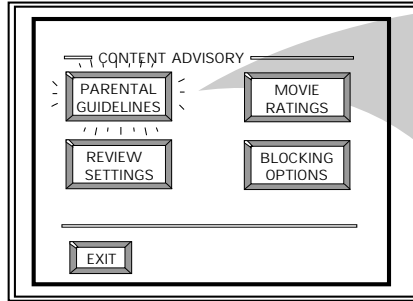

- **TV-Y - Appropriate for all children:** Designed for a very young audience, including children ages 2-6. This type of programming is not expected to frighten younger children.
  - **TV-Y7 - Appropriate for children seven and older:** It may be more appropriate for children who have acquired the development skills needed to distinguish between make believe and reality. This programming may include mild fantasy and comic violence (FV).
  - **TV-G - General Audience:** This type of programming contains little or no violence, no strong language, and little or no sexual dialogue or situations.
  - **TV-PG - Parental Guidance suggested:** This type of programming contains one or more of the following: Moderate violence (V), some sexual situations (S), infrequent coarse language (L), or some suggestive dialogue (D).
  - **TV-14 - Unsuitable for children under 14:** This type of programming contains one or more of the following: intense violence (V), intense sexual situations (S), strong coarse language (L), or intensely suggestive dialogue (D).
  - **TV-MA - Mature audience only:** This type of programming contains one or more of the following: graphic violence (V), explicit sexual situations (S), or crude indecent language (L).
- **(V) - Violence**
  - **(S) - Sexual situations**
  - **(L) - Language**
  - **(D) - Inappropriate dialogue**
  - **(FV) - Fantasy Violence** may frighten children under seven. Some cartoons may have this rating. Available in the TV Y7 category only.

# FEATURE MENU CONTROLS (CONTINUED)

## CONTENT ADVISORY BLOCKING OPTIONS

The Content Advisory system also has “Blocking Option” controls which can be used to deny viewing access for channel programs and movies even when they are “unrated”, or contain “no rating” information as broadcasted.

### (BEGIN)

#### 1 Select the **BLOCKING OPTIONS** Menu control.

With CONTENT ADVISORY Menu on screen, move the RED highlight with the outer OK arrow buttons. Then press the center OK button to select the feature.

#### 2 Press the OK arrow and center OK buttons to turn the Blocking System On (highlight and select ENABLED). Then use the remote OK arrow buttons to select the desired programming and information blocking options.

Please refer to Note shown with this page section for details on “unrated” and “no rating” program control options.

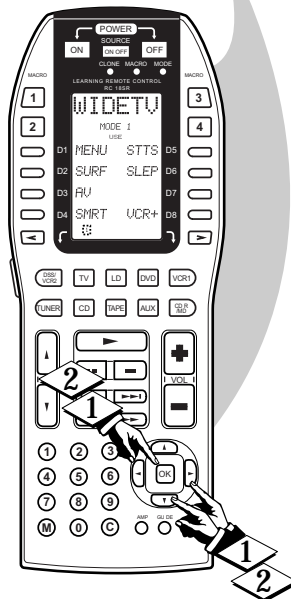
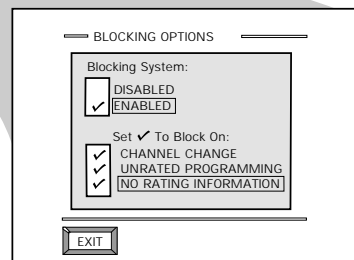
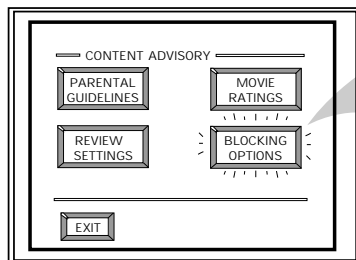

Note: Remember that Content Advisory data or encoded information is not available with all received TV programming (this also includes commercials, and other program spot announcements). Broadcaster's can decide **not to encode** any kind of content advisory ratings with their programming, or they can actually choose to **encode programs to be “unrated.”**

The TV Blocking Options allow the viewer to block any program without content advisory data with the use of its “NO RATING INFORMATION” control. And to block programs that are encoded as “unrated” with its “UNRATED PROGRAMMING” control option.

Since the reception of Content Advisory data can take a few seconds, you may want to use the “CHANNEL CHANGE” option to be sure no viewing is allowed during blocked program channel changes. This can eliminate the display of a few seconds of undesirable video on the TV, or receiving scenes from a Ratings blocked channel source.

## CONTENT ADVISORY REVIEW SETTINGS

Use the Review Settings control to quickly check the status for Content Advisory system Parental Guidelines and Movie Rating “Blocked” program levels.

### (BEGIN)

#### 1 Select the **REVIEW SETTINGS** Menu option.

With CONTENT ADVISORY Menu on screen, move the RED highlight with the outer OK arrow buttons. Then press the center OK button to select the feature.

The TV screen will display the current Parental Guideline and Movie Ratings Blocked program settings. Content Advisory system status will also be shown (Enabled - On, or Disabled - Off).

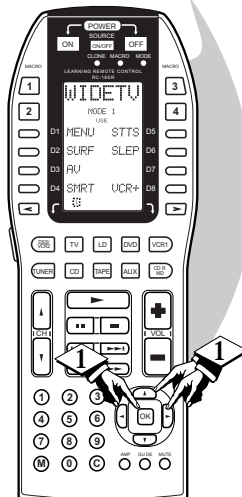
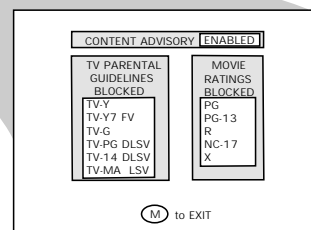
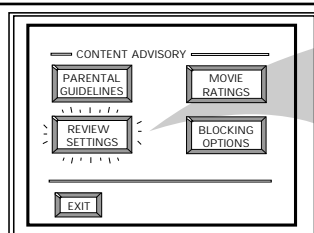



# FEATURE MENU CONTROLS (CONTINUED)

## CHANNEL LABELS

Do you ever have trouble remembering on which channel a particular station or network is located? The Channel Labels Control is a quick way to view and select channels from a list of Labeled channels.

A Label is a four letter callout you can set to appear with the on screen channel number. Example Label: WXYZ for a TV station's call letters.

To select channels from the Channel Labels Control:

### (BEGIN)

- 1 With the **FEATURE MENU** (3 of 5) on the TV screen, move the **RED highlight** with the outer OK arrow buttons. Then press the center OK button to select **CHANNEL LABELS**.
- 2 Press the **OK arrow** and **center OK** buttons to highlight and select either:
  - "**MANUAL**" to create your own label for a channel.
  - "**PRESETS**" to choose from a list of prewritten channel labels.
 (See instruction details on this page.)
- 3 Press the **STATUS** button to clear the screen.

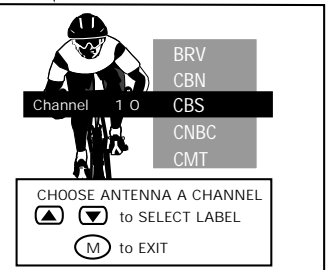
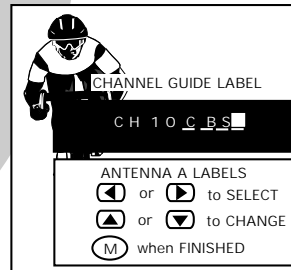
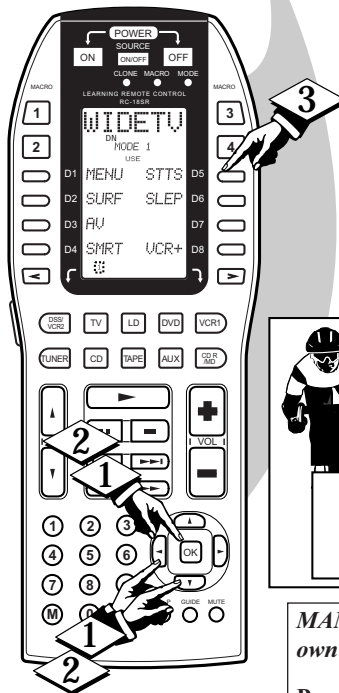
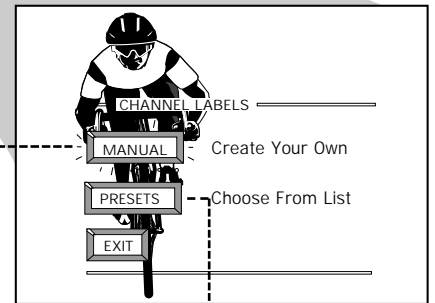
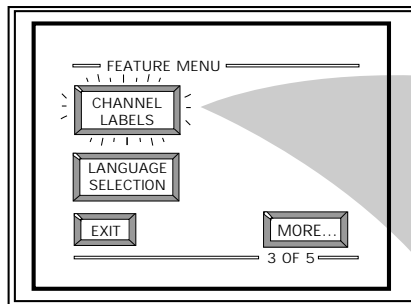

### MANUAL To create your own Channel Label:

Press the **Channel ▲▼** or **Number** buttons to select desired station.

A **red highlight** shows the active letter space for the channel label.

Press the **outer OK arrow (top or bottom)** buttons on the remote to pick any of the letters or symbols that are given for your use.

Press the **outer OK arrow (Left and Right)** buttons on the remote to move the red highlight to the other letter spaces and repeat.

Press the **STATUS** button to clear the screen when finished.

### PRESETS To pick a Label from the "LABEL" list:

Press the **Channel ▲▼** or **Number** buttons to select desired station.

Press the **outer OK arrow (top or bottom)** buttons to move up and down the Channel Label list.

**Just stop** on any label you might want to use.

The selected label automatically appears with channel changes and when the **STATUS** button is pressed.

Press the **STATUS** button to clear the screen when finished.

# FEATURE MENU CONTROLS (CONTINUED)

## LANGUAGE

**Note:** If you went through First Time Setup, this task has already been completed for you.

For our Spanish and French speaking TV owners an on screen LANGUAGE option is present. With the LANGUAGE control you can set the TV's on screen features to be shown in either English, Spanish or French.

### BEGIN

#### 1 Select the LANGUAGE DISPLAY control.

With FEATURES MENU (3 of 5) on screen, move the RED highlight with the outer OK arrow buttons. Then press the center OK button to select the feature.

#### 2 Press the OK arrow and center OK buttons to highlight and select (✓) English, Español, or Français on the display control.

Text for the on-screen Menu will change to the selected language.

#### 3 Press the STATUS button to clear the screen.



## SMART HELP



Remember, the Language control only makes the TV's on-screen (MENU) items appear in English, Spanish, or French text. It does not change the other on-screen text features such as Closed Captioned (CC) TV shows.

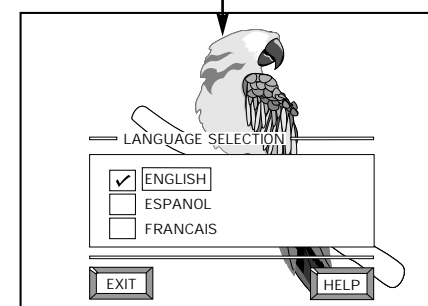
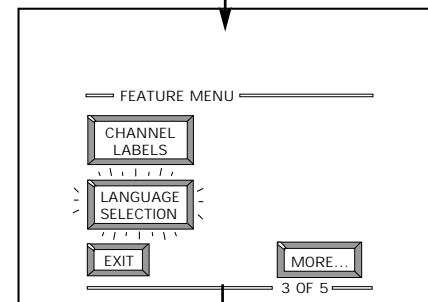
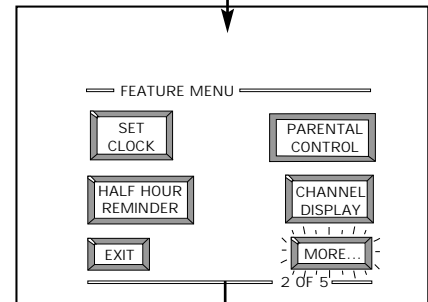
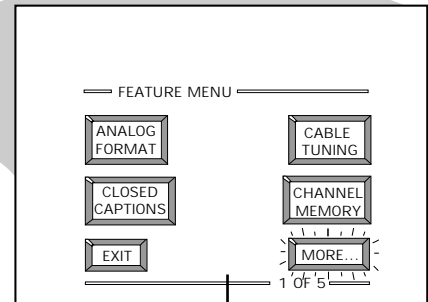
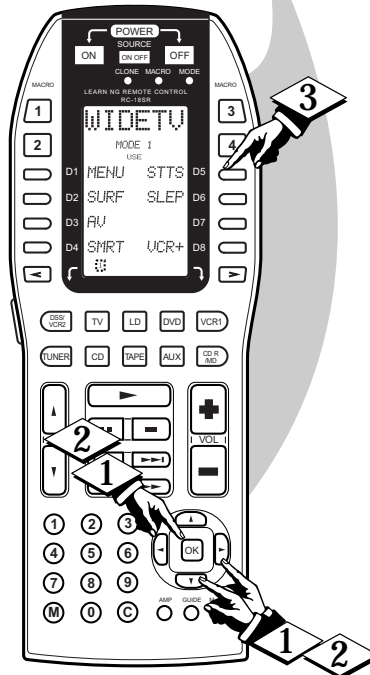
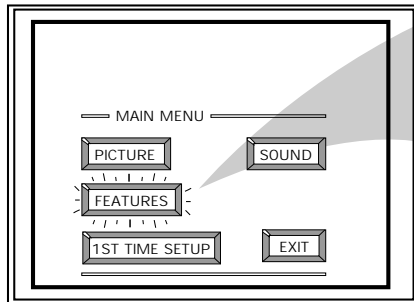

# SOUND MENU CONTROL ADJUSTMENTS



## BASS, TREBLE, BALANCE

Your TV also has individual sound adjustment controls. The **BASS** (low frequency), **TREBLE** (high frequency), and **Speaker BALANCE** may all be used to adjust the sound playback of TV programs.

### BEGIN

- 1 Select **BASS**, or **TREBLE**, or **BALANCE** sound control.

With the **SOUND MENU** on the screen, move the **RED** highlight with the outer **OK** arrow buttons. Then press the center **OK** button to select the feature.

- 2 Press the outer **OK** arrow (**Left** and **Right**) buttons to adjust the sound control to levels you prefer.

- 3 Press the **STATUS** button to clear the screen.

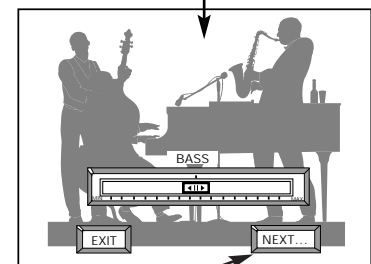
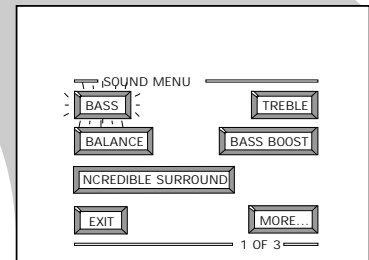
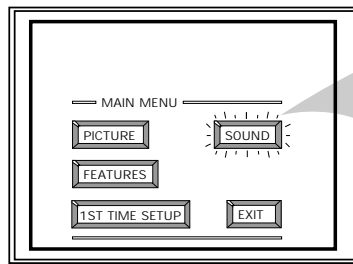

Select "Next" and then press the **MENU (M)** button to view and adjust additional Audio controls. For Example: Treble, Balance, etc.

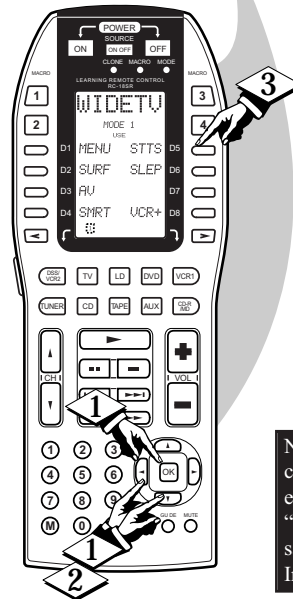

Note: Audio Menu controls can be set separately dependent upon the current TV operating mode (NTSC/ANTENNA, AUX 4, AUX 5, etc.). For instance, the TV Speaker On/Off control can be set to "ON" for normal NTSC TV viewing playback operation; while the same Audio control can also be set to "OFF" in a AUX 4 or AUX 5 Input Source mode.

## BASS BOOST

The **BASS BOOST** control increases the low frequency audio range of the TV. This creates a deeper, fuller playback sound which can be heard through the TV's speakers.

### BEGIN

- 1 Select **BASS BOOST** sound control.

With the **SOUND MENU** on the screen, move the **RED** highlight with the outer **OK** arrow buttons. Then press the center **OK** button to select the feature.

- 2 Press the **OK** arrow and center **OK** buttons to highlight and turn **ON** (✓) the **BASS BOOST** control.

- 3 Press the **STATUS** button to clear the screen.

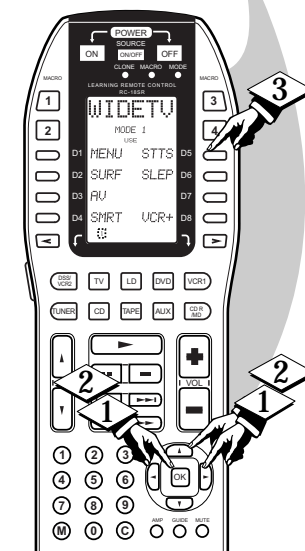
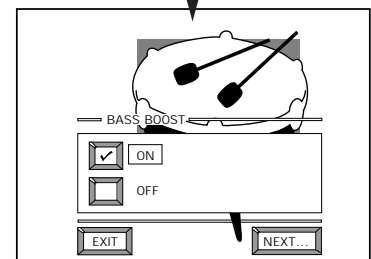
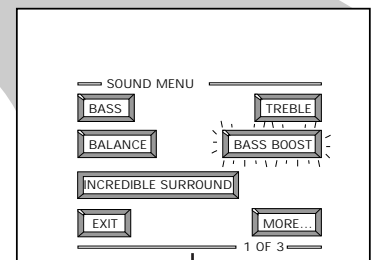
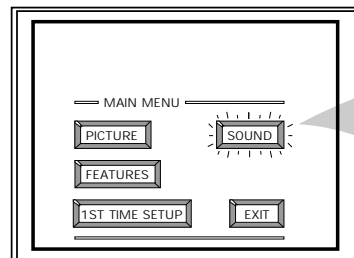

# SOUND MENU CONTROLS (CONTINUED)

## STEREO

Your TV is able to receive broadcast stereo TV programs. The TV is equipped with an amplifier and twin speaker system through which the stereo sound can be heard.

Note: STEREO will appear on the TV's channel status screen to indicate when a stereo broadcast signal is available and received.

### (BEGIN)

- 1 Select **STEREO** sound control. With the **SOUND MENU** on the screen, move the **RED** highlight with the outer **OK** arrow buttons. Then press the center **OK** button to select the feature.
- 2 Press the **OK** arrow and center **OK** buttons to highlight and turn **ON** (✓) the **STEREO** mode.
- 3 Press the **STATUS** button to clear the screen.

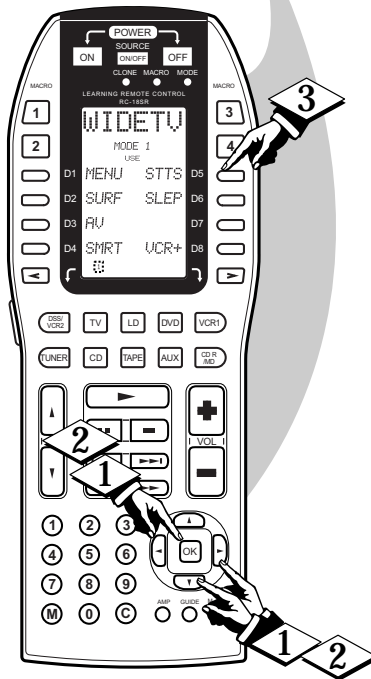
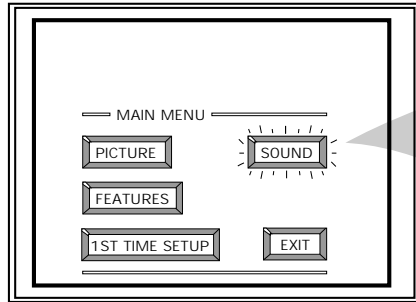

## SMART HELP



Remember. If a stereo signal is not available and the TV is placed in the **STEREO** mode, sound coming from the TV will remain monaural (mono).

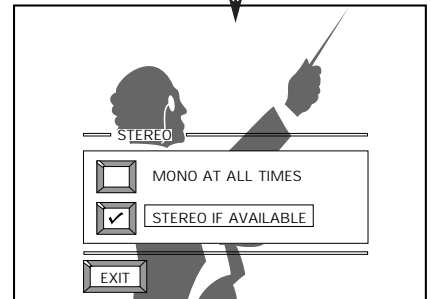
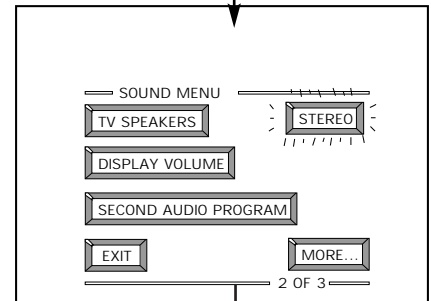
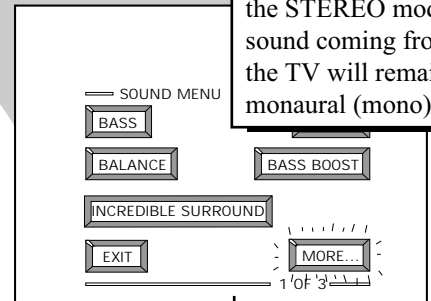

## SECOND AUDIO PROGRAM

Second Audio Program (SAP) is part of the stereo broadcast system. Sent as an additional audio channel SAP can be heard apart from the current TV program sound. TV stations are free to use SAP for any number of purposes, but many experts believe it will be used for foreign language translations of TV shows (or for weather and news bulletins.)

NOTE: If a SAP signal is not present with a selected program, the SAP option can not be selected. "This program does not contain SAP information" will show on the TV screen.

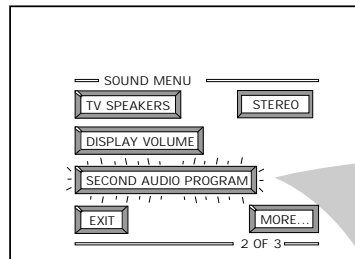

SECOND PROGRAM SOUND CAN ONLY BE SELECTED (✓) WHEN SAP INFORMATION IS PRESENT ON CURRENT CHANNEL.

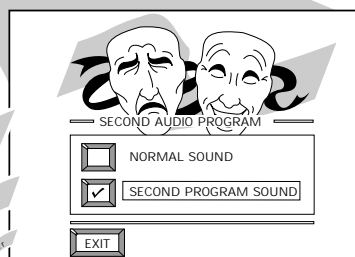

news and today's

news and today's

# SOUND MENU CONTROLS (CONTINUED)

## INCREDIBLE SURROUND

The Incredible Surround control can be used to add greater depth and dimension to both monaural (MONO) and STEREO TV sound.

### BEGIN

- 1 Select the INCREDIBLE SURROUND control.

With the SOUND MENU on the screen, move the RED highlight with the outer OK arrow buttons. Then press the center OK button to select the feature.

- 2 Press the OK arrow and center OK buttons to highlight and turn ON (✓) the INCREDIBLE SURROUND mode.

- 3 Press the STATUS button to clear the screen.

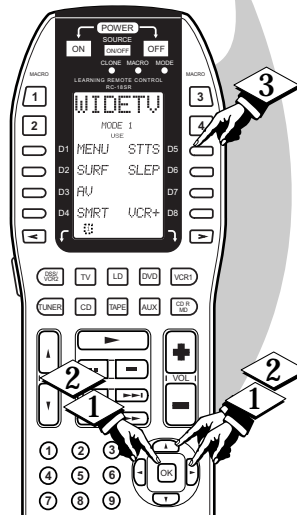
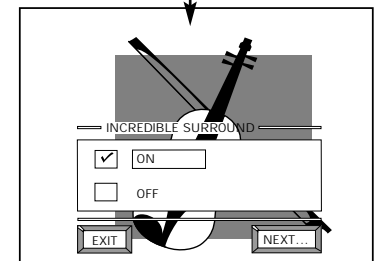
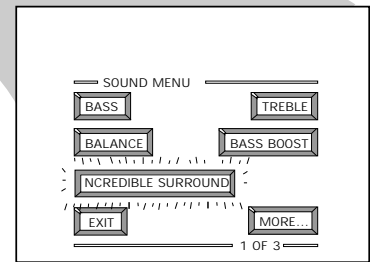
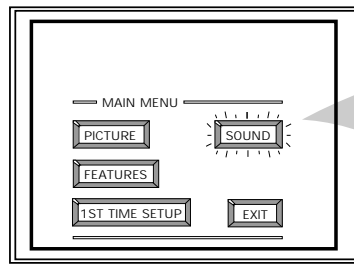

## DISPLAY VOLUME

Use the DISPLAY VOLUME control to see the TV's volume level settings on the TV screen. Once set the Volume Display will be seen each time the VOLUME buttons (on the TV or remote) are pressed.

### BEGIN

- 1 Select DISPLAY VOLUME control.

With SOUND MENU (2 of 3) on screen, move the RED highlight with the outer OK arrow buttons. Then press the center OK button to select the feature.

- 2 Press the OK arrow and center OK buttons to highlight and turn ON (✓) the DISPLAY VOLUME control.

- 3 Press the STATUS button to clear the screen.

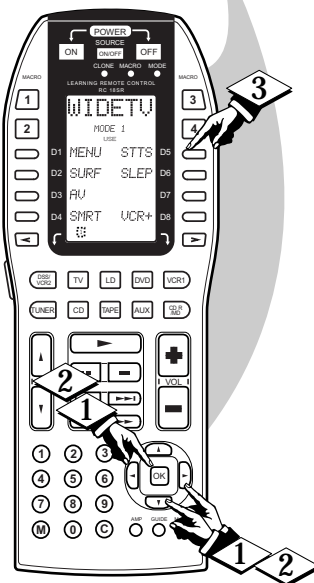
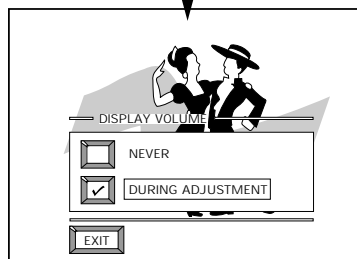
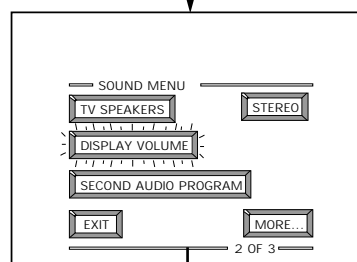
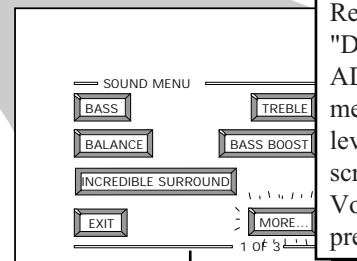
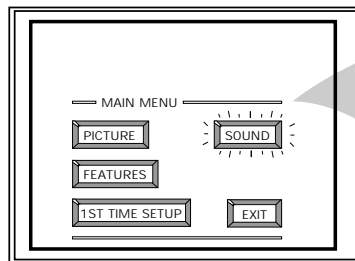

## SMART HELP



Remember, "DURING ADJUSTMENT" means the volume level will be on screen whenever the Volume buttons are pressed.

# SOUND MENU CONTROLS (CONTINUED)

## TV SPEAKERS

Would you like to hear TV programs through your audio hi fi system? The TV's Variable Audio Output jacks and TV Speaker On/Off control work together to offer you this TV sound option.

### BEGIN

- 1 Connect the R(ight) and L(eft) VARIABLE AUDIO OUT jacks on the TV to the R and L Audio Input jacks on your amplifier or sound system.

Set the audio system's volume to normal listening level.

- 2 Turn the TV and audio system ON. You can now adjust the sound level coming from the audio system with the Volume ▲▼ buttons on the TV or remote.

- 3 To hear the TV sound from only the audio system speakers, select TV SPEAKERS control.

With SOUND MENU (2 of 3) on screen, move the RED highlight with the outer OK arrow buttons. Then press the center OK button to select the feature.

- 4 Press the OK arrow and center OK buttons to highlight and turn OFF (↗) the TV SPEAKERS control.

You should now only hear TV sound coming from the audio system speakers.

- 5 Press the STATUS button to clear the screen.



### SMART HELP



Remember, the audio system may have to be in AUX(iliary) mode to play sound from the TV (Outputs).

Note: When the TV SPEAKER control is set to "NORMAL" (for TV speaker operation) make sure the VARIABLE AUDIO OUTPUT control (see next page) is also set to "STEREO" in order for the TV's AUDIO OUTPUT jacks to work properly.

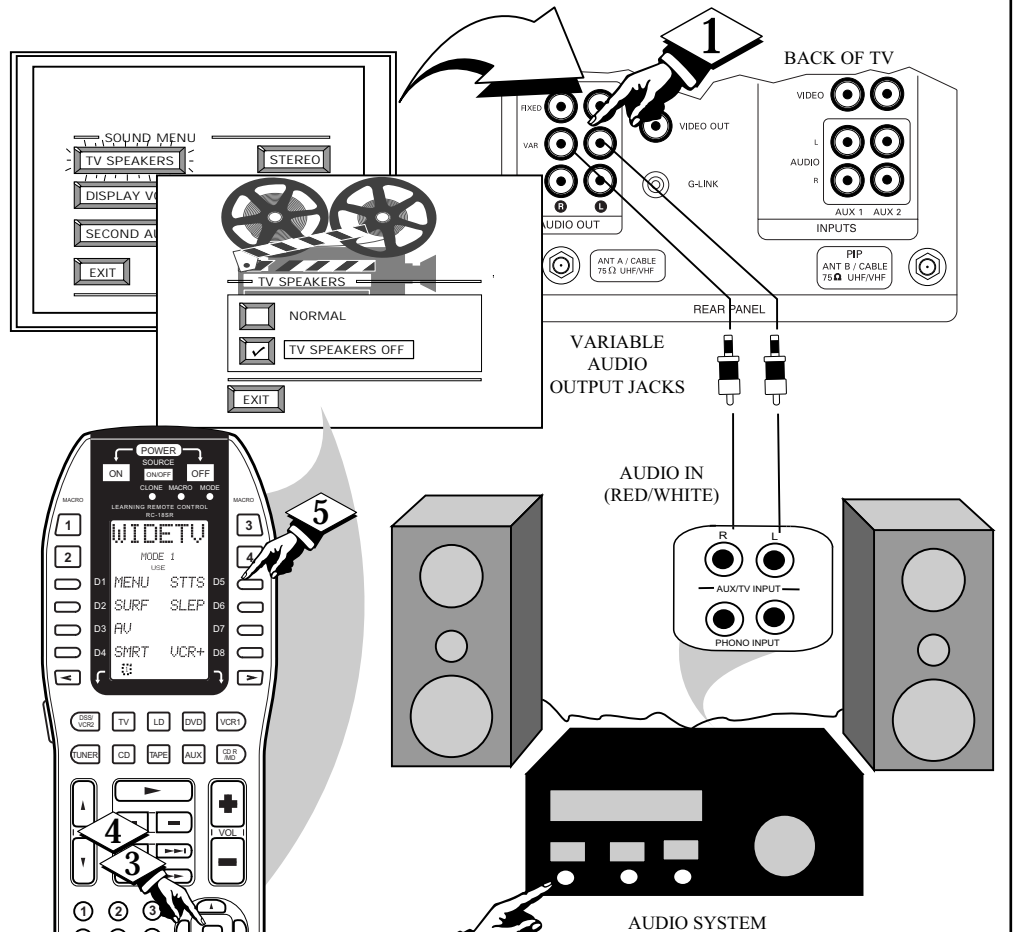

Note: Audio Menu controls can be set separately dependent upon the current TV operating mode (NTSC/ANTENNA, AUX 4, AUX 5, etc.). For instance, the TV Speaker On/Off control can be set to "OFF" for normal NTSC TV viewing playback operation; while the same TV Speaker Audio control can also be set to "ON" in a AUX 4 or AUX 5 Input Source mode.

**NOTE:** The TV's FIXED AUDIO OUTPUT jacks can also be used for the playback of TV program sound with an external audio amplifier, or home theater hi fi system. Connection of the FIXED AUDIO OUT(puts) is similar

to the Variable Audio Outputs (as shown above). However, specific sound level adjustments will be made with the controls at the external amplifier or home sound system (instead of through the TV's audio level controls.)

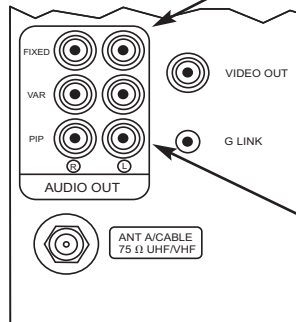

**NOTE:** The TV's PIP AUDIO OUTPUT jacks can also be used for additional stereo playback options such as wireless transmitter headphone hook up, or as an external amplifier connection source. However, with normal PIP feature operations (when

the ANT A and ANT B Input sources are connected for use), the PIP AUDIO OUTPUTS will switch from stereo to monaural (mono) sound. Stereo sound will only be available with the TV's Main screen (or ANT A supplied signal) at that time.

# SOUND MENU CONTROLS (CONTINUED)

## SURROUND SOUND

By adding optional external speakers to the TV's sound system, you can create the feeling of reflected sound that surrounds you at a movie theater or concert hall.

**BEGIN**

- 1 Connect both external speakers to the speaker wire terminals on the TV.

Recommended speakers: 8 ohm, 15 watt minimum. Be sure the (+) and (-) speaker wires are connected to the correct R(ight) and L(ef) speaker terminals on the TV.

- 2 Place the speakers so the viewing area is between the TV and the rear surround speakers. (See overhead view drawing.)

- 3 Turn TV ON and place the STEREO control to the "STEREO IF AVAILABLE" (✓) position.

After setup whenever a stereo signal is received the audio will be heard in Surround Sound.

**STOP**

## SMART HELP



Remember, Surround Sound will not work with only one speaker connected; or with monaural audio material (unless Variable Audio Surround control is turned ON - see section below).

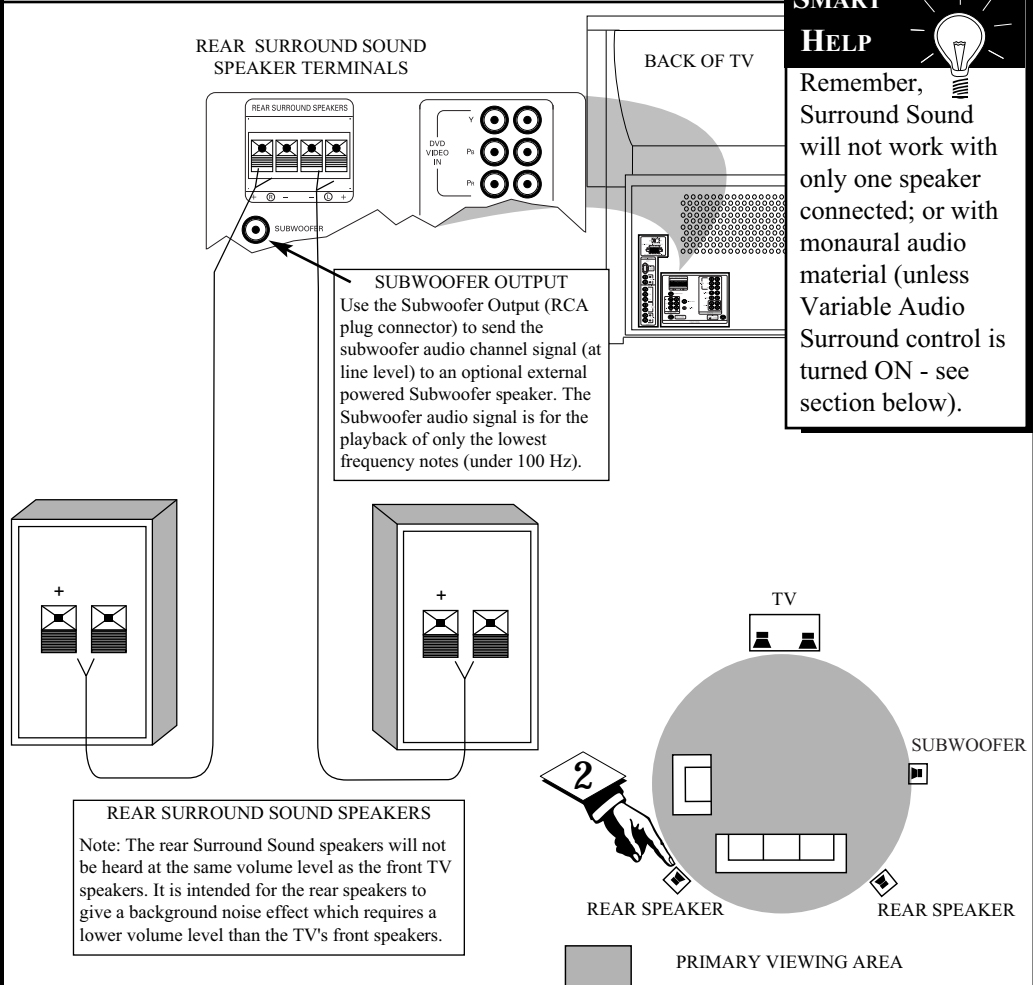

## VARIABLE AUDIO OUTPUT

The TV's Variable Audio Output jacks can also be used for Surround Sound. Once they are connected to an external hi fi system its speakers can be used for the playback of Surround Sound.

**BEGIN**

- 1 Connect the R(ight) and L(ef) VARIABLE AUDIO OUT jacks on the TV to the R and L Audio Input jacks on your amplifier or sound system.

- 2 Turn TV ON and place the VARIABLE AUDIO OUTPUT on screen control to the SURROUND (✓) position. (Sound Menu 3 of 3).

Note: This will change the Left/Right channel audio line level signal at the Audio Output jacks to the same signal found at the TV's Surround Sound Speaker terminals.

**STOP**

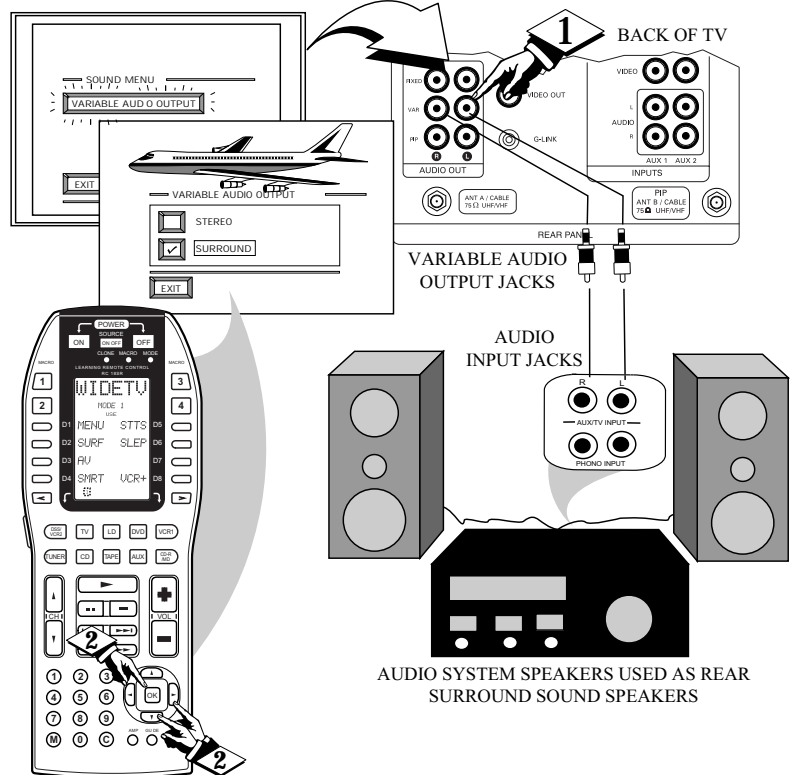

# OPTIONAL SURROUND SOUND CONNECTIONS

*Extra speaker connections have been supplied on the rear of the TV. These extra connections are especially important for some of the optional Amplifier and multi speaker arrangements that are possible with Dolby Pro Logic Surround Sound audio features.*

**For example:** With the Surround mode multiple speakers are needed to complete the setup for proper DOLBY SURROUND sound playback-

- 2 Front Left/Right Speakers
- 1 Center Channel Speaker
- 2 Rear Surround Speakers

The Front Left/Right, Center, and Rear Surround Speakers have their signals supplied by the connections located on the back of the Dolby ProLogic Audio Receiver.

Note: A CENTER CHANNEL AMP(plifier) INPUT is also located on the TV. This input can be used to connect the external Audio Receiver's Center Channel Output in order to play Center Channel sound through the internal TV speakers.

When an Audio Receiver is used as the audio source for the CENTER CHANNEL AMP INPUT:

- Place the TV's AMP SWITCH to the EXTERNAL position

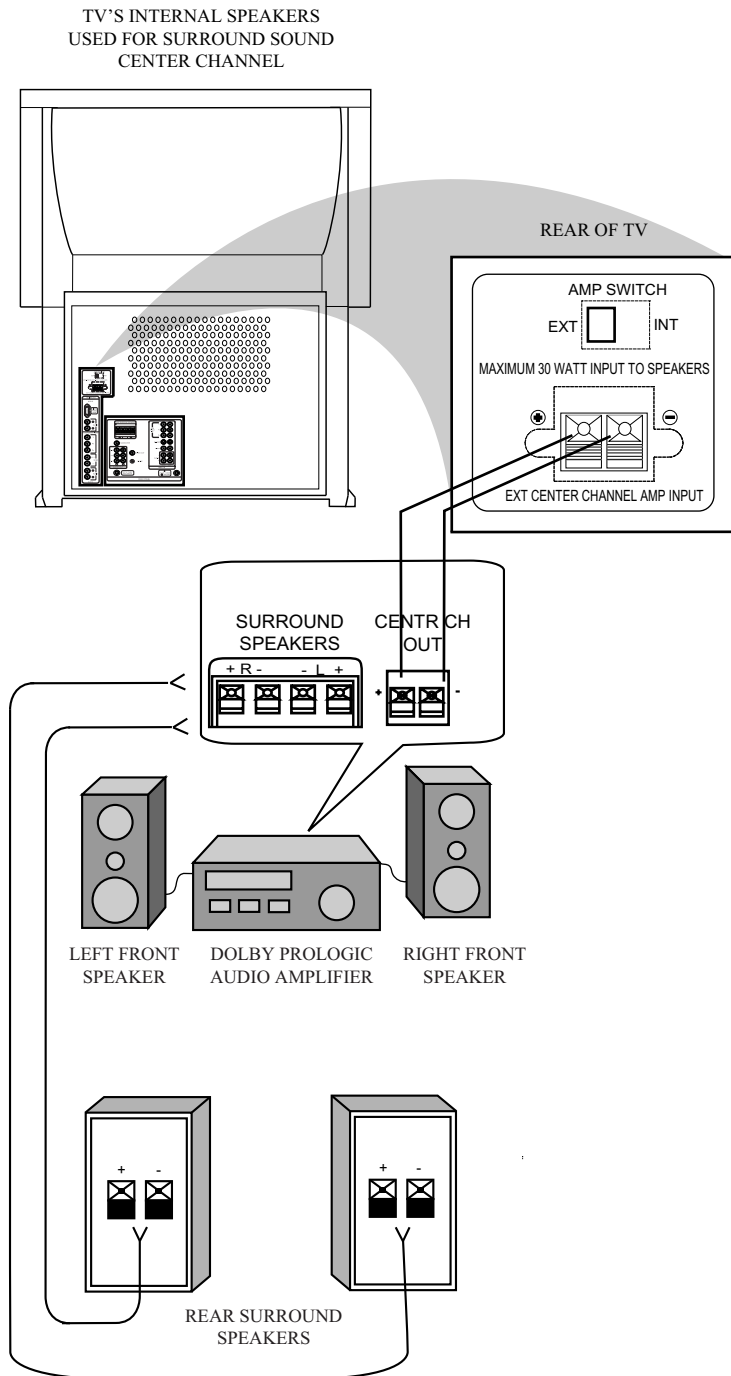



# USING THE AUDIO/VIDEO INPUT JACKS

## AUX 1 VIDEO INPUTS

The TV's Audio/Video Input jacks are for direct picture and sound connections between the TV and a DVD (or VCR, etc.) that has Audio/Video (Composite) Output jacks.

To view the playback of a DVD program disc by using the Audio/Video Input jacks on the TV:

### BEGIN

- 1 **Connect the VIDEO OUT** jack from the DVD to the AUX 1 VIDEO IN jack on the TV.
- 2 **Connect the AUDIO OUT** jacks R(ight) and L(eft) from the DVD to the AUX 1 AUDIO IN jacks on the TV.
- 3 **Select the "AUX 1 DVD VIDEO" Picture Source control** on the TV.  
Press the A/V button on the remote (or the Source Select button on the front of the TV) to display the TV's Input Source control screen.
- 4 **Press the OK arrow** and **center OK** buttons to highlight and select (✓) the AUX 1 DVD VIDEO mode.
- 5 **Turn the DVD ON** and press **PLAY** to view the playback disc tape on the TV.



PICTURE AND SOUND FROM  
PLAYBACK OF DVD

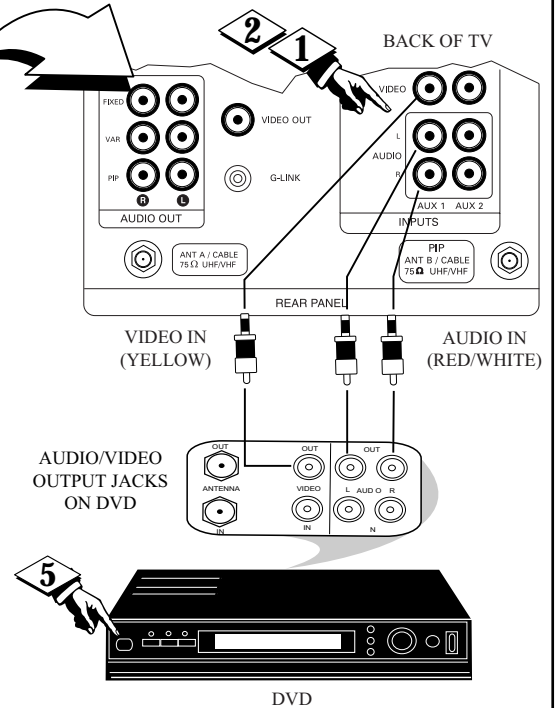
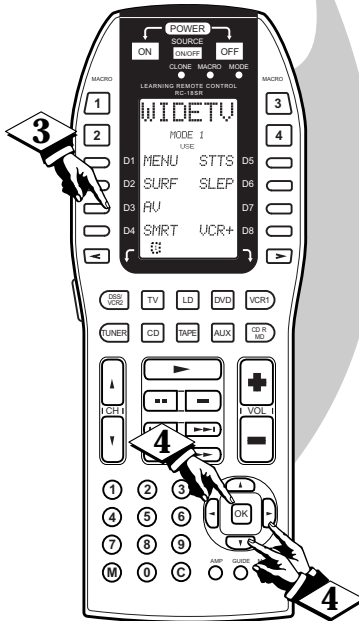
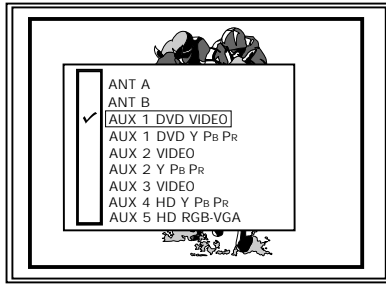

NOTE: Connections and use of the TV's rear AUX 2 VIDEO Input jacks are the same as for the AUX 1 jacks (except "AUX 2 VIDEO" is selected as the Picture Source in step 3).

## SMART HELP



Remember, if you have need for any connecting cables or devices contact your dealer or our Parts Information center (1-800-851-8885) to order any optional accessories.

# USING THE AUDIO/VIDEO INPUT JACKS (CONTINUED)

## AUX 3 VIDEO INPUTS

For more convenient Direct playback connections the TV's Side Video (AUX 3) Input panel can be used. Located on the TV's right side panel (angled toward the front for easy access) these Audio/Video Input jacks allow for quick connections, particularly for the playback of Camcorder tape recordings.

To view the playback of a Camcorder recording using the Audio/Video Input jacks on the side of the TV:

### BEGIN

- 1 Connect the VIDEO OUT jack from the Camcorder to the VIDEO IN jack on the side of the TV.
- 2 Connect the AUDIO OUT jacks R(ight) and L(eft) from the Camcorder to the AUDIO IN jacks on the side of the TV.
- 3 Select the "AUX 3 VIDEO" Picture Source control on the TV. Press the A/V button on the remote (or the Source Select button on the front of the TV) to display the TV's Input Source control screen.
- 4 Press the OK arrow and center OK buttons to highlight and select the AUX 3 VIDEO mode.
- 5 Turn the Camcorder ON and press PLAY to view the tape on the TV.



## SMART HELP

Remember, if you have a single (monaural) Audio Output Camcorder, "Y" connectors are available to complete your connection. Contact your dealer or our Parts Information center (1-800-851-8885) to order any optional accessories.

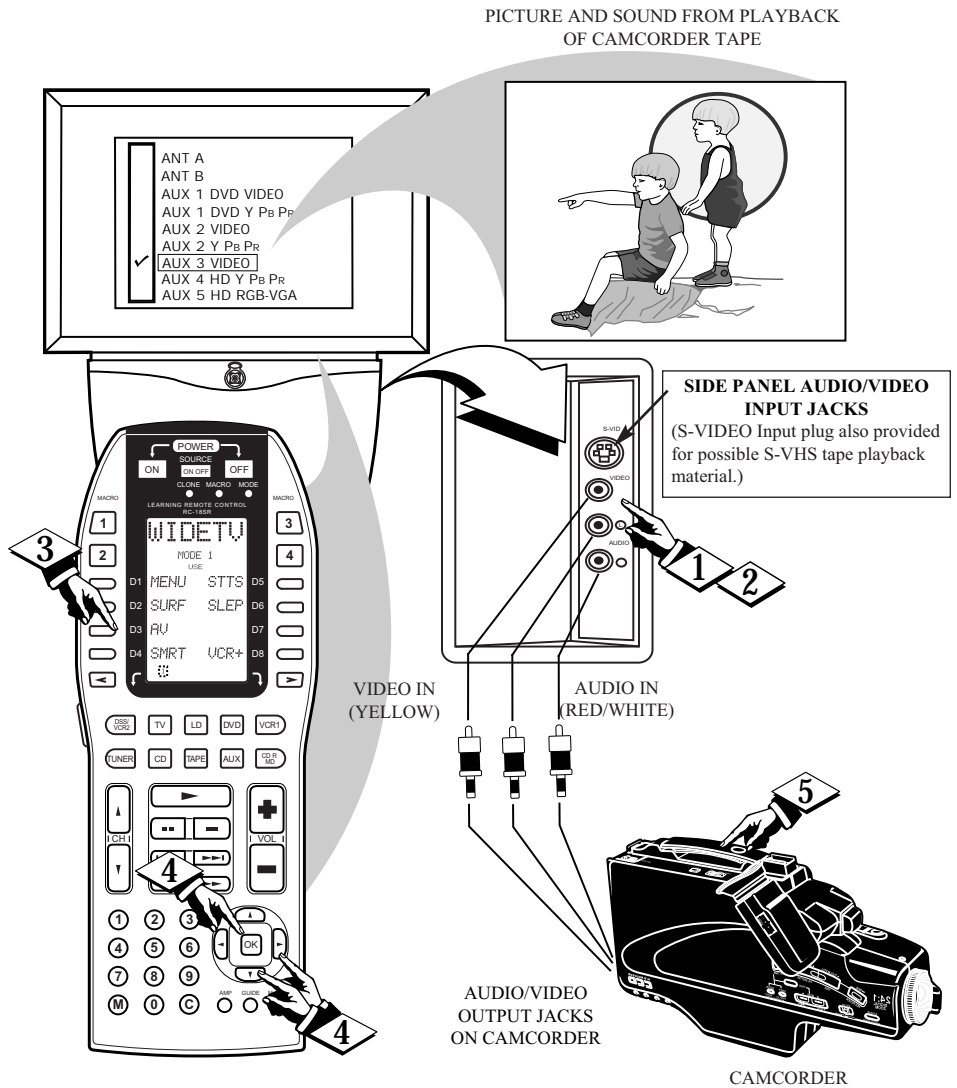

# USING THE AUDIO/VIDEO INPUT JACKS (CONTINUED)

## AUX 1 - S-VIDEO INPUTS

The S(uper) Video connection on the rear (and Side Panel) of the TV can give you better picture detail and clarity for the playback of S VHS VCR tapes or DVDs than the normal antenna (RF Signal) or Video (Composite) picture connections.

Note: The VCR or DVD Player must have a S VIDEO OUT(put) jack in order for you to complete the connections shown on this page.

### BEGIN

- 1 **Connect the S-VIDEO (S-VHS) OUT** jack from the VCR to the S-VIDEO AUX 1 IN(put) jack on the TV.

The S-VIDEO connecting cable will be supplied with the S-VHS VCR (or DVD Player).

- 2 **Connect the AUDIO OUT** jacks R(ight) and L(eft) from the VCR to the AUDIO AUX 1 IN(put) jacks on the TV.

- 3 **Select the "AUX 1 S-VIDEO" Picture Source** control.

Press the A/V button on the remote (or the Source Select button on the front of the TV) to display the TV's Input Source control screen.

The "AUX 1 S-VIDEO" picture source option appears only when a S-VIDEO cable has been connected to the TV's AUX 1 IN(puts).

- 4 **Press the OK arrow and center OK** buttons to highlight and select the AUX 1 S-VIDEO mode.

- 5 **Turn the VCR ON** and place it in the S-VIDEO (or S-VHS) playback mode. Insert S-VHS cassette tape and playback in a normal manner.



PICTURE AND SOUND FROM PLAYBACK OF S-VHS VCR TAPE

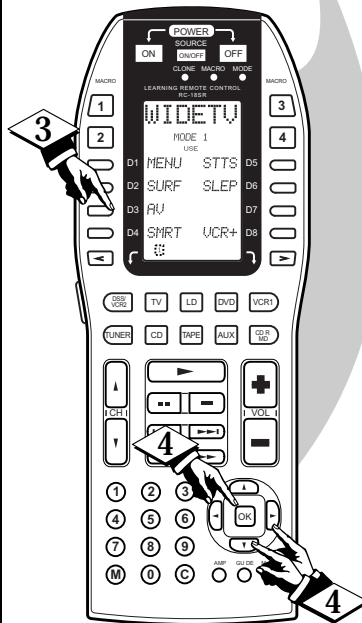
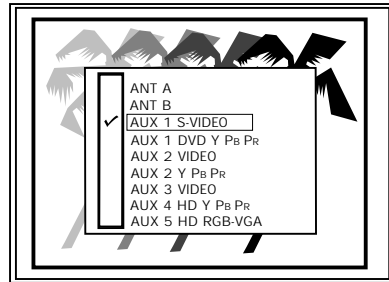

NOTE: Connections and use of the TV's AUX 2 and AUX 3 S-VIDEO Input jacks are the same as for the AUX 1 S-VIDEO jacks (except "AUX 2 or AUX 3 S-VIDEO" is selected as the Picture Source in step 3).

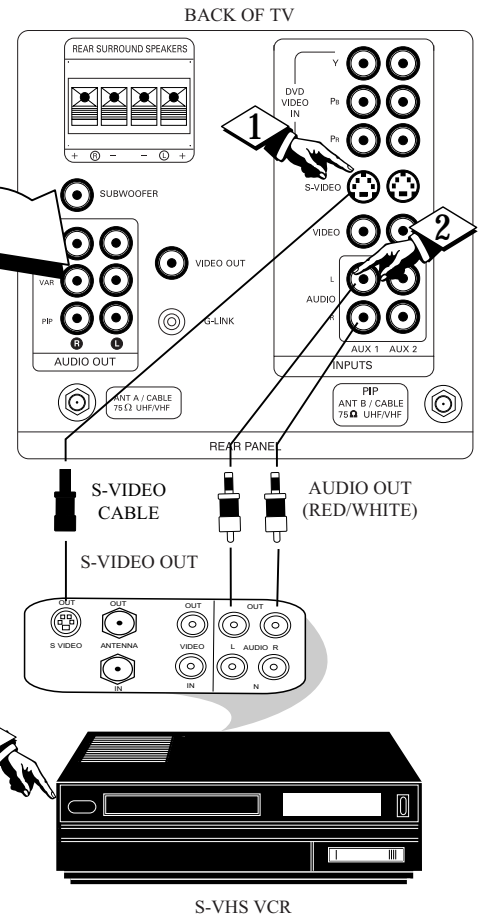

NOTE: A CD-i (Compact Disc Interactive) player, Video Game, or other S-VIDEO accessory can be hooked up to the TV using this type of connection. Please be aware that such video sources, which show a constant non-moving pattern on the TV screen, can cause picture tube damage. When not in use turn your video accessories OFF. Also, regularly alternate the use of video sources with normal TV viewing.

# USING THE AUDIO/VIDEO INPUT JACKS (CONTINUED)

## COMPONENT VIDEO INPUTS

Component Video Inputs provide for the highest possible color and picture resolution in the playback of digital signal source material such as with DVD players. The color difference signals (PB, PR) and the luminance (Y) signal are connected and received separately which permits for improved color bandwidth information (not possible when using composite video or S Video connections).

### BEGIN

- 1 **Connect the Component (Y Pb Pr) VIDEO OUT** jacks from the DVD player to the (Y Pb Pr) VIDEO IN(put) jacks on the TV.
- 2 **Connect the AUDIO OUT** jacks R(ight) and L(eft) from the DVD player to the AUX 1 AUDIO IN jacks on the TV.
- 3 **Select the "AUX 1 Y Pb Pr" Picture Source** control on the TV. Press the A/V button on the remote (or the Source Select button on the front of the TV) to display the TV's Input Source control screen.
- 4 **Press the OK arrow and center OK buttons** to highlight and select (✓) the AUX 1 Y Pb Pr mode.
- 5 **Turn the DVD player ON** and press PLAY to view the source material playback on the TV.



## SMART HELP

The description for the component video connectors may differ depending on the DVD player or accessory digital source equipment used (e.g. Y Pb Pr; R Y/B Y/Y; Cr/Cb/Y, etc.). Although abbreviations and terms may vary, the letters "B" and "R" stand for the blue and red color component signal connectors, and "Y" indicates the luminance signal. Refer to your DVD or digital accessory Owner's Manual for definitions and connection details.

PICTURE AND SOUND FROM PLAYBACK OF DVD SOURCE MATERIAL

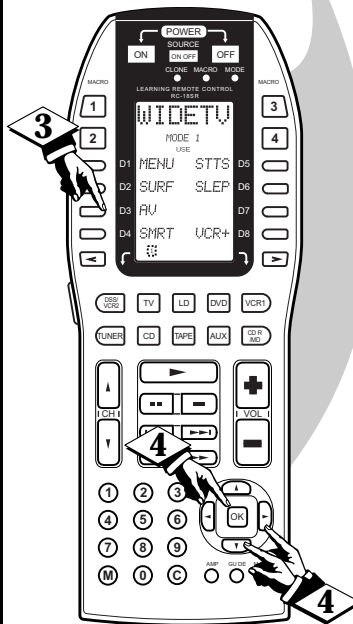
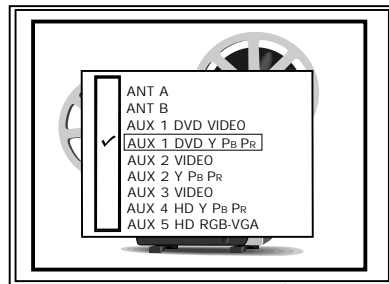

NOTE: Connections and use of the TV's rear AUX 2 Y Pb Pr Input jacks are the same as for the AUX 1 jacks (except "AUX 2" Y Pb Pr is selected as the Picture Source in step 3).

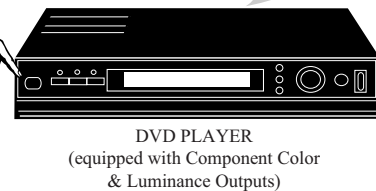
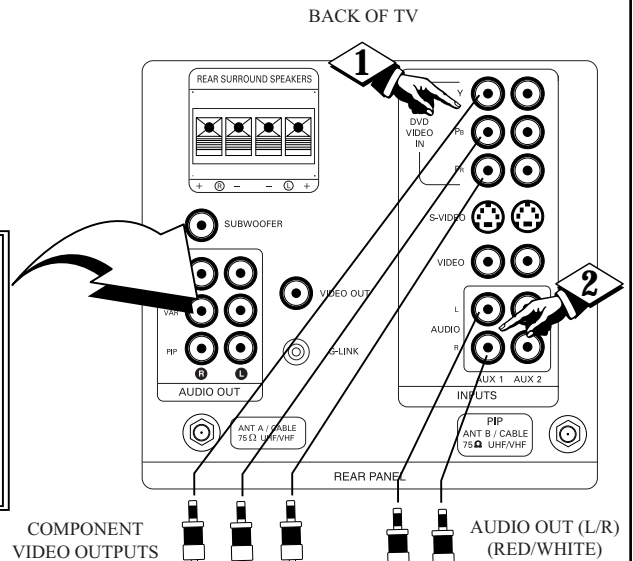

Optional Video/Audio Cables (with standard RCA plug connectors) are available to complete your Component Input Jack connections. Contact your dealer, or our Parts Information Center (1-800-851-8885) to order any optional accessories.

# USING THE AUDIO/VIDEO OUTPUT JACKS (CONTINUED)



## AUDIO/VIDEO OUTPUTS

The Audio/Video Output jacks on the TV can be used to record TV programs on VCRs which have Audio/Video Input jacks.

To record TV programs by using the Audio/Video jacks on the TV:

### BEGIN

- 1 Connect the VIDEO OUT jack from the TV to the VIDEO IN jack on the VCR.
- 2 Connect the AUDIO OUT jacks R(ight) and L(eft) from the TV to the AUDIO IN jacks on the VCR.
- 3 Select the "ANTENNA A" Picture Source control on the TV. Press the A/V button on the remote (or the Source Select button on the front of the TV) to display the TV's Input Source control screen. Press the OK arrow and center OK buttons to highlight and select (✓) the ANTENNA A mode.
- 4 Select the channel on the TV that you want to record.
- 5 Turn the VCR ON. Put a cassette tape in the unit and place the VCR in the RECORD mode.



PICTURE AND SOUND BEING RECORDED ON VCR.

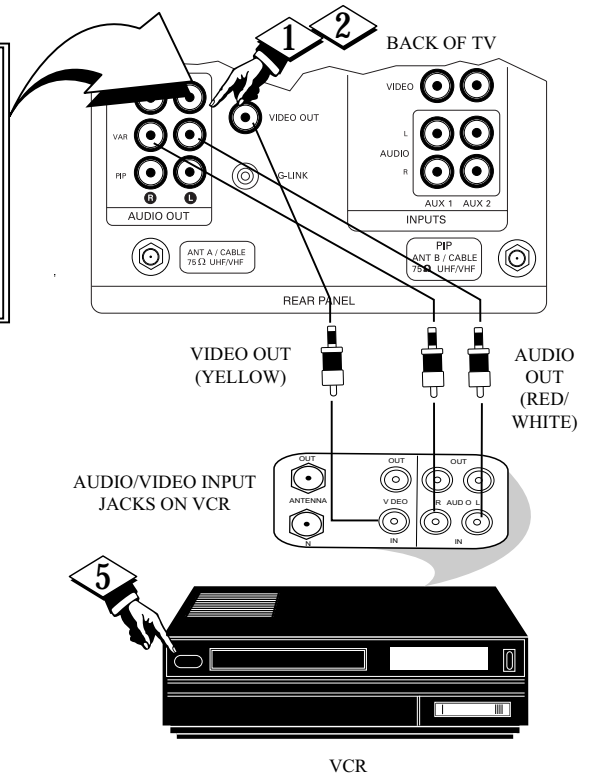
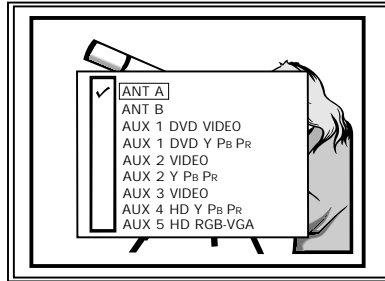

## SMART HELP



Remember, If the VCR has an INPUT SELECTOR switch, place it in the LINE or CAMERA position.

Unattended Timer Recordings with a VCR are possible, but not recommended with this connection since the TV must be left ON for the VCR to record.

# MONITOR FEATURES MENU CONTROLS

## VGA/RGB/HDCOMPONENT

Another function with your TV is for the connection and use of Personal Computers (PCs), and other High Definition (HD) digital source equipment (through the use of TV's Monitor inputs and display mode). Dedicated HD Audio Input jacks (located on the rear of the TV) are also paired to the external source Monitor Video Inputs (VGA and HD Component Video In) for audio playback connections as well.

For example: To connect a Philips DVX8000 Multimedia Home Theater (MMHT) for monitor mode display use on the TV:

### BEGIN

- 1 **Connect a 15 pin VGA signal cable (optional)** from the VGA (or SVGA) jack on the select auxiliary equipment (example: DVX8000 MMHT) to the VGA Input jack on the TV.
- 2 **Connect the Left/Right HD INPUT AUDIO IN jacks** on the TV to the (L/R) Audio Output jacks (labeled Front) on the DVX8000 MMHT.
- 3 **Press the A/V button on the remote (or the Source Select button on the front of the TV) to select the AUX 5 HD RGB/VGA Monitor Input mode.**  
**Press the OK arrow and center OK buttons to highlight and select the AUX 5 HD RGB/VGA mode.**
- 4 **Use the DVX8000 MMHT as the video (and/or audio) playback source for material to be displayed on the TV's screen.**

### SMART HELP

Note: The TV's video display may temporarily appear misconverged during the initialization of certain VGA input connected PC programs (i.e., DOS). Once the PC program has completed its "bootup" phase, normal signal level processing will reoccur and the TV display will return to normal.

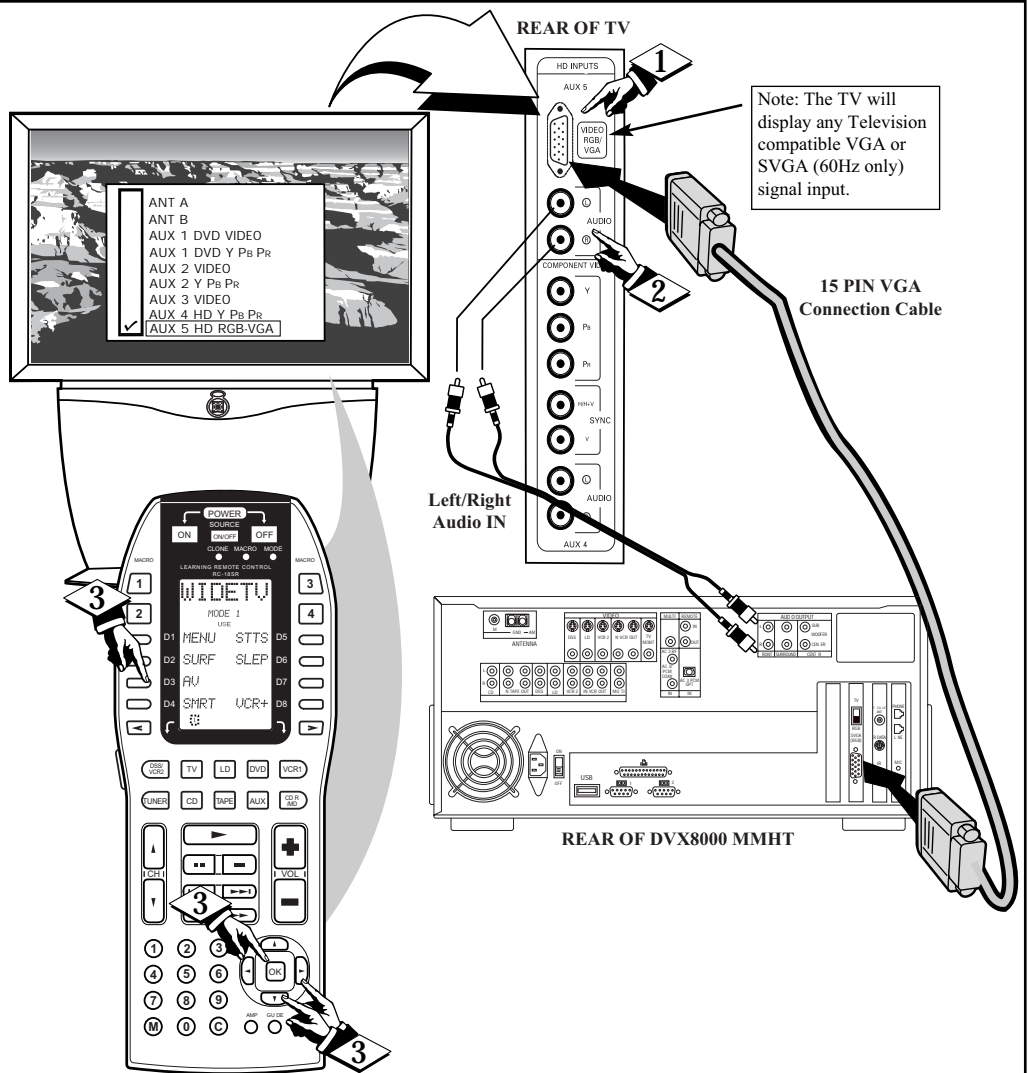

## HD COMPONENT VIDEO IN

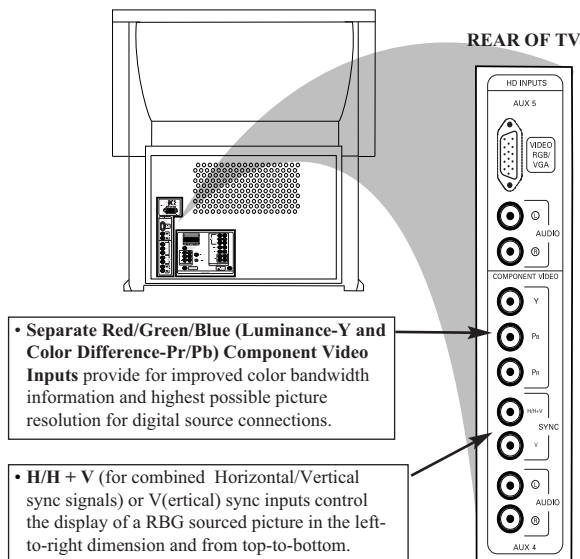

# MONITOR FEATURES MENU CONTROLS



## MONITOR MENU CONTROLS

The Monitor Menu feature controls are to aid you in setting up the TV for the best in display image quality. Generally, the Monitor feature controls cover the basics in color and video image screen adjustments. A variety of Monitor Audio Input controls are also available for various TV speaker sound adjustments. (See the Audio Adjustments note to the right for further details on AUX(iliary) and NTSC/Antenna mode sound controls.

### BEGIN

- 1 Press the A/V button (or the Select Source button on the front of the TV) to place the TV in the desired High Definition (HD) display mode (AUX 4 HD Y PB PR; or AUX 5 HD RGB-VGA).
- 2 Press the OK arrow buttons to choose any of the individual controls you wish to adjust for the selected HD mode. Then press the center OK button to select the highlighted control.
- 3 Press the OK arrow and center OK buttons to adjust the selected control.
- 4 Press the STATUS button on the remote to clear the screen after you have finished with all of your feature control adjustments.



### SMART HELP

Certain barscale Monitor Feature Menu adjustments (such as Brightness, Picture, etc.) will display separate control panel screens for individual settings. Repress the OK button on the remote (or Menu on the local keyboard) to return the TV to the Monitor Menu when control adjustments are complete.

Note: The list of Monitor Menu features (and their individual control settings) will change or readjust according to the capabilities of the selected Display Mode (AUX 4, AUX 5, etc.).

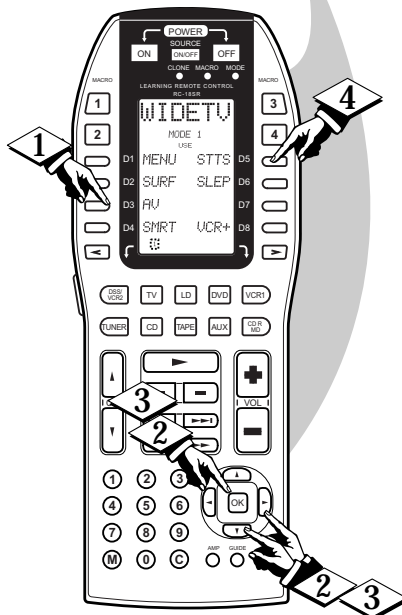
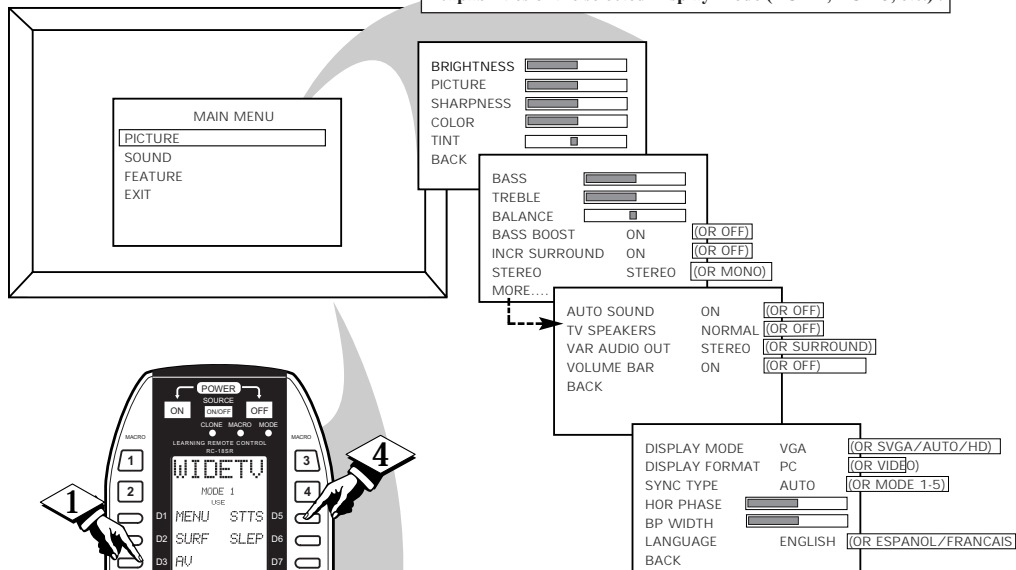

Note: Audio Menu controls can be set separately dependent upon the current TV operating mode (NTSC/ANTENNA, AUX 4, AUX 5, etc.). For instance, the TV Speaker On/Off control can be set to "ON" for normal NTSC TV viewing playback operation; while the same Audio control can also be set to "OFF" in a AUX 4 or AUX 5 Input Source mode.

- Use the **Brightness** and other Monitor picture features (such as Picture, Sharpness, etc.) to adjust overall TV screen intensity for optimum light/dark screen areas and shading details.
- Turn the **Volume Bar** Sound Menu control ON to display the volume level settings for external audio sourced material on the TV screen.
- Select the **Bass/Treble/Balance** Sound Menu controls to adjust low/high frequency sound and speaker balance for external input audio source material played through the TV's audio system.
- Use the **Display Mode and Format** Feature Menu controls to set the TV for the type of external monitor display mode source (VGA, AUTO, SVGA, EXT HD); and the TV's display screen format used (PC, NORMAL, WIDESCREEN).
- **Additional Sync Type, Horizontal Phase, Back Porch (BP) Width** Feature Menu controls can be used to adjust for color shifts, black level, and various other display screen imagery.
- Use the **LANGUAGE** control to set the HD Menu control screens for English, Spanish (Español), or French (Français) language term displays.

# REMOTE CONTROL OPERATION

## SMART/AUTO PICTURE

With Auto Picture you can set a number of video and audio controls to your own personal preference. Once the individual controls have been adjusted to the levels you desire, use the list of Auto Picture feature category titles to quickly reselect these “personalized” settings contained within the memory of the TV. (See the next page for more details on the labeling options and use of Auto Picture.)

### BEGIN

- 1 Press the **SMART/AUTO** button on the remote (LCD Display D4 - button).

Press the center OK button on the remote to select the Auto Picture feature (highlighted in RED).

- 2 Press the **outer OK arrow** buttons to highlight the category list for Auto Picture. Press the center OK button to select (✓) the desired title.

- 3 Press the **OK arrow** buttons to choose any of the individual controls you wish to adjust for the Auto Picture selected title. Then press the center OK button to select the highlighted control.

- 4 Press the **OK arrow** and **center OK** buttons to adjust the selected control.

- 5 Press the **STATUS** button on the remote to clear the screen after you have finished with all of your Auto Picture feature control adjustments.

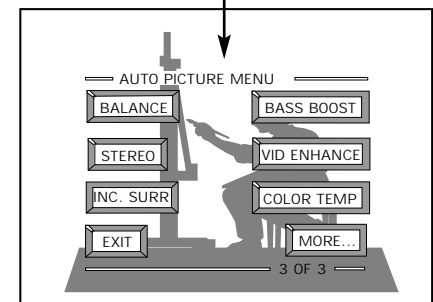
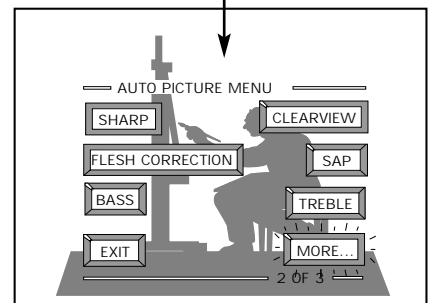
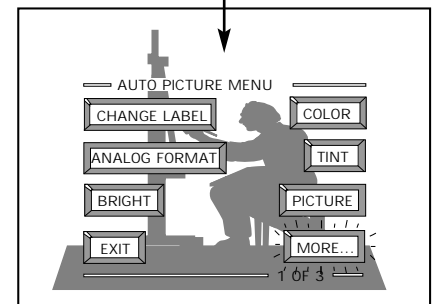
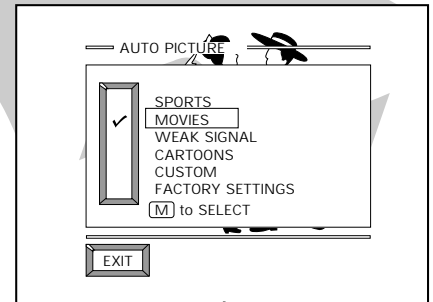
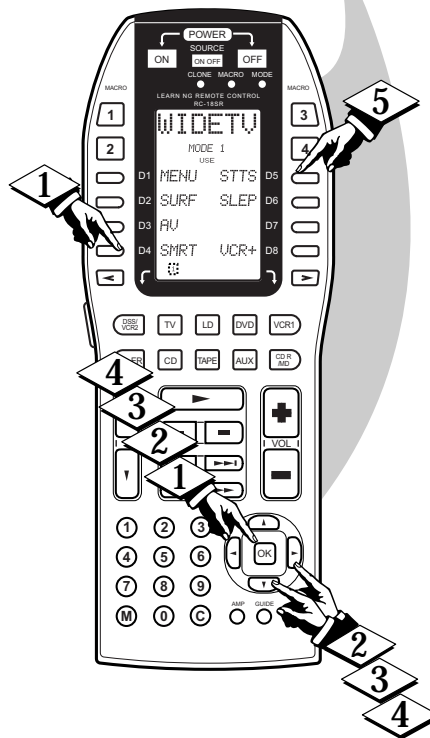
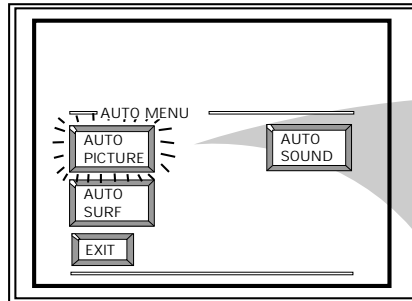

## SMART HELP



Note: Select the “FACTORY SETTINGS” category to automatically return the TV to the video and audio control levels preset at the factory prior to product shipment.



# REMOTE CONTROL OPERATION (CONTINUED)



## SMART/AUTO PICTURE

Following your initial setup adjustments (see previous page), just select the desired Auto Picture category in order to place the TV to the personalized set of audio and video control settings for that title.

### BEGIN

- 1 Press the **SMART/AUTO** button on the remote.

Then press the center **OK** button to select the **AUTO PICTURE** control feature.

- 2 Press the **outer OK arrow** buttons with the list of "AUTO PICTURE" categories on the TV screen to highlight the desired category. Then press the center **OK** button to select the audio and video control settings for that particular title.

- 3 Press the **STATUS** button on the remote to clear the screen.

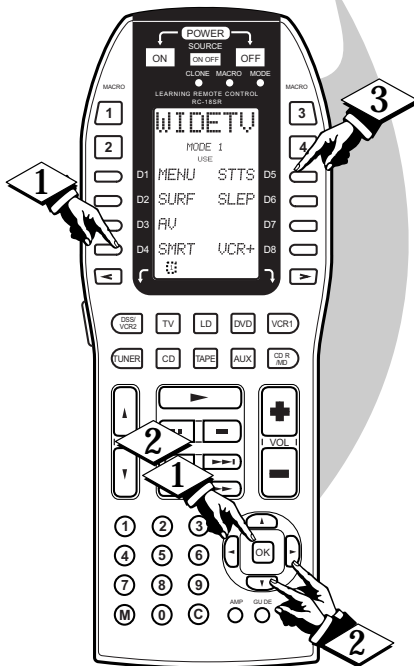
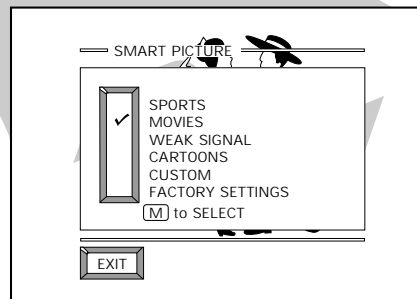
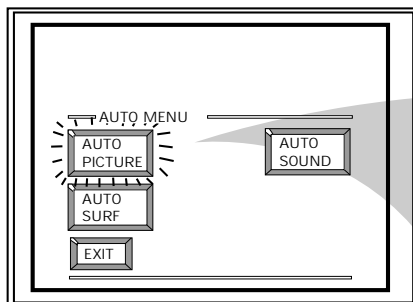

## CHANGE LABEL

The "CHANGE LABEL" control can be used to change the title of a **AUTO PICTURE** setting into a name or label that may be easier for you to remember.

### BEGIN

- 1 With the **AUTO PICTURE** "CHANGE LABEL" control on the screen, press the **outer OK arrow (top and bottom)** buttons to spell out a new label or title for the selected **AUTO PICTURE** category.
- 2 Press the **outer OK arrow (left and right)** buttons to move the red highlight to each letter space.
- 3 Press the **STATUS** button to clear the screen when the new label is finished.

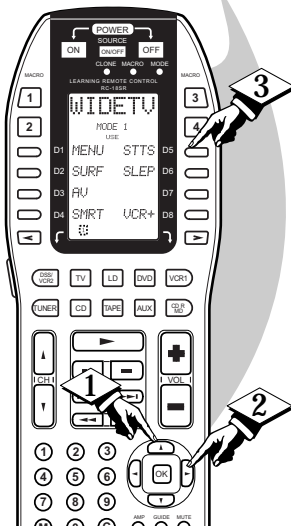
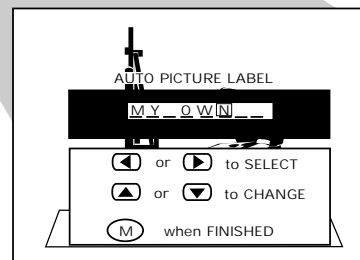
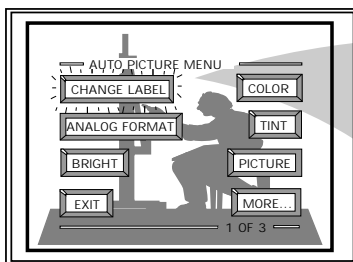

# REMOTE CONTROL OPERATION (CONTINUED)

## SMART/AUTO SOUND

Are you tired of the sound of commercials following you throughout the house? Auto Sound allows you to preset a desired volume level that the TV sound will not go above. This makes for an even, more consistent sound by reducing the “peaks” and “valleys” that can occur during commercials.

### BEGIN

- 1 Press the **SMART/AUTO** button on the remote.
- 2 With the **AUTO Menu** on screen, move the **RED** highlight with the outer **OK** arrow buttons. Then press the center **OK** button to select the highlighted Auto Sound control.
- 3 Press the **OK** arrow and the center **OK** buttons to turn the Auto Sound control **ON** (or **OFF**.)
- 4 Press the **STATUS** button to clear the screen when completed.



## SMART HELP



Remember, Auto Sound works for sound levels coming from either the Antenna/Cable input on the rear of the TV (RF audio); or the Auxiliary (VCR/AUX IN) audio inputs.

When using a Cable Converter Box with the Auto Sound Control ON, the TV's volume level may take up to ten seconds to gradually increase to normal listening levels (when the TV's first turned on). This is considered **NORMAL** with various Cable Converter Box use.

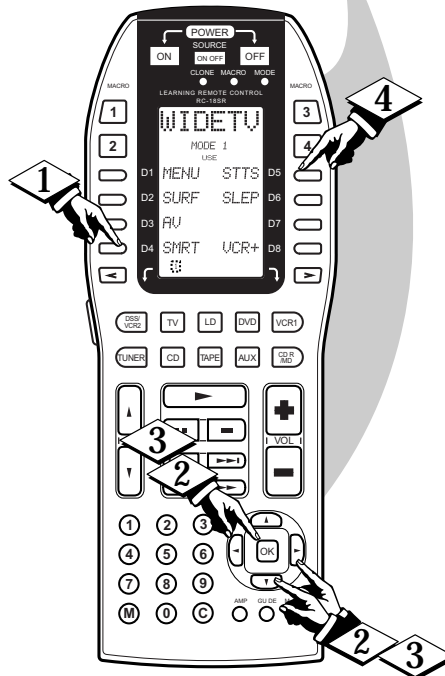
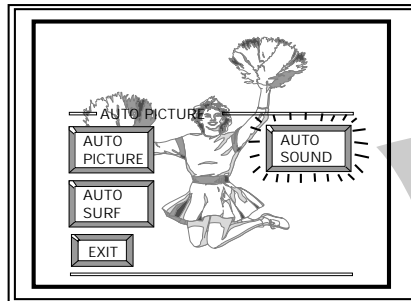

# REMOTE CONTROL OPERATION (CONTINUED)



## 2-CHANNEL SURF/AUTO SURF

A "list" or series of previously viewed channels can be selected with the SURF button on your remote control. With this feature you can easily switch between different TV programs that currently interest you. The Auto Surf control allows you to set up to 10 channels in its quick viewing "list".

### BEGIN

- 1 Press the SMART/AUTO button on the remote.
- 2 With the AUTO Menu on screen, move the RED highlight with the outer OK arrow buttons. Then press the center OK button to select the highlighted Auto Surf control.
- 3 Press the OK arrow then the center OK button to select either Auto Surf or 2-Channel Surf. (See explanation of Surf options with the illustration on this page.)
- 4 Press STATUS button on the remote control to clear the screen.

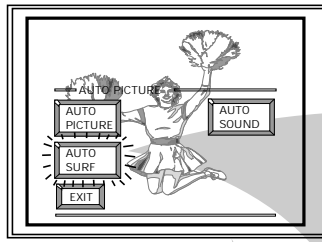

**2 CHANNEL SURF**- Current and one previous channel in the ring.

**AUTO SURF** - Current and up to nine additional channels available in the ring. Note: The Channel Surf ring can be used with fewer than ten channels. In this way, the number of Surf channels can match or fit your present viewing interests.

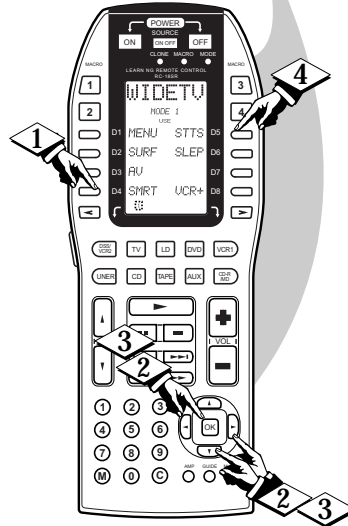

## SMART HELP



**To Use 2-Channel Surf:**  
With the 2-Channel Surf control ON, select the two desired channels for viewing with the number buttons on the remote control. Then press the SURF button on the remote to "toggle" between the two selected channels.

## HOW TO USE AUTO SURF

### BEGIN

- 1 With the Auto Surf control ON (see above), select a desired channel for viewing. You can use the number buttons on the remote (or the Channel ▲▼ buttons).
- 2 Press the SURF button on the remote. (Some channel numbers may already appear within the Surf channel list.)
- 3 Press the center OK button to "ADD" the selected channel to the Surf list.  
Select the next desired channel and repeat steps 2 and 3. Continue until all desired channels are on the Surf list.
- 4 Press the SURF button on the remote to quickly review current action on channels contained within the Surf list.

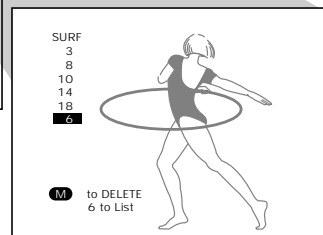
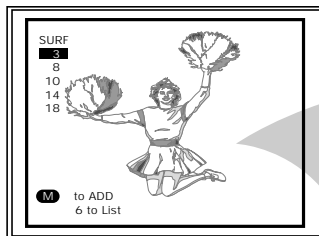

Note: To Delete a channel from the Surf list just press the SURF button to select the desired channel. Then press the Menu (or center OK) button and the channel will be immediately dropped from the on-screen Surf list.

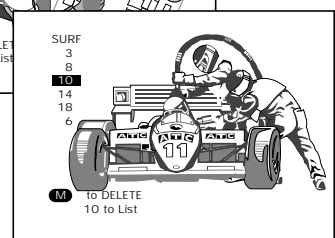
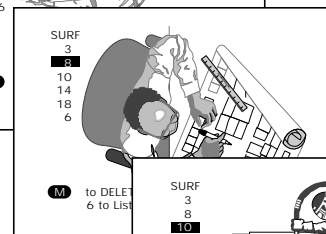
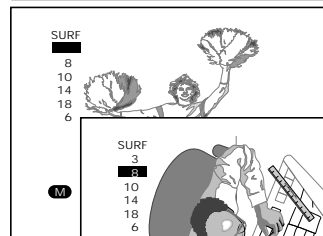
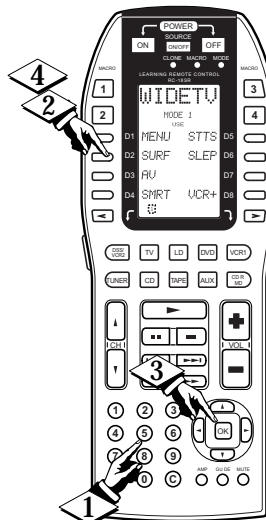

# HOW TO USE THE PICTURE-IN-PICTURE (PIP) FEATURE

**P**icture in Picture (PIP) is the showing of two pictures on the TV screen at the same time. (One main screen picture and one small inset picture or PIP). For your ease and convenience this TV has two separate inputs (ANTenna A and ANTenna B) for your home's Antenna and/or Cable TV system signal.

**The ANT A input is primarily for the TV's main screen picture.**

**The ANT B input is provided as a second, dedicated source option for the TV's PIP "window" and its feature operations.** The signal connected to the ANT B input can be either a Split Signal Input (as described in the section on this page), or another type of external signal source (such as a satellite dish system, additional home antenna, video accessory, etc.).

See the following steps on how channels connected to the ANT(enna) B Input can be shown and used within the PIP window:

## BEGIN

**1** Connect your Antenna or Cable TV signal to the single 75 ohm INPUT plug on a two-way Signal Splitter (not supplied).

Connect two lengths of RF Coaxial Cable (F-type connectors on both ends) to the two OUTPUT plugs on the two-way Signal Splitter.

**2** Connect the twin OUTPUT plugs on the Signal Splitter to the ANT A and ANT B Inputs on the rear of the TV.

*continue to next page*

## SMART HELP



For other possible PIP connections see page 53 for the "More PIP Connections" section.

If you need any accessories or parts to complete the described PIP connections, contact your dealer, or our Parts Information Center at (1-800-851-8885) for details.

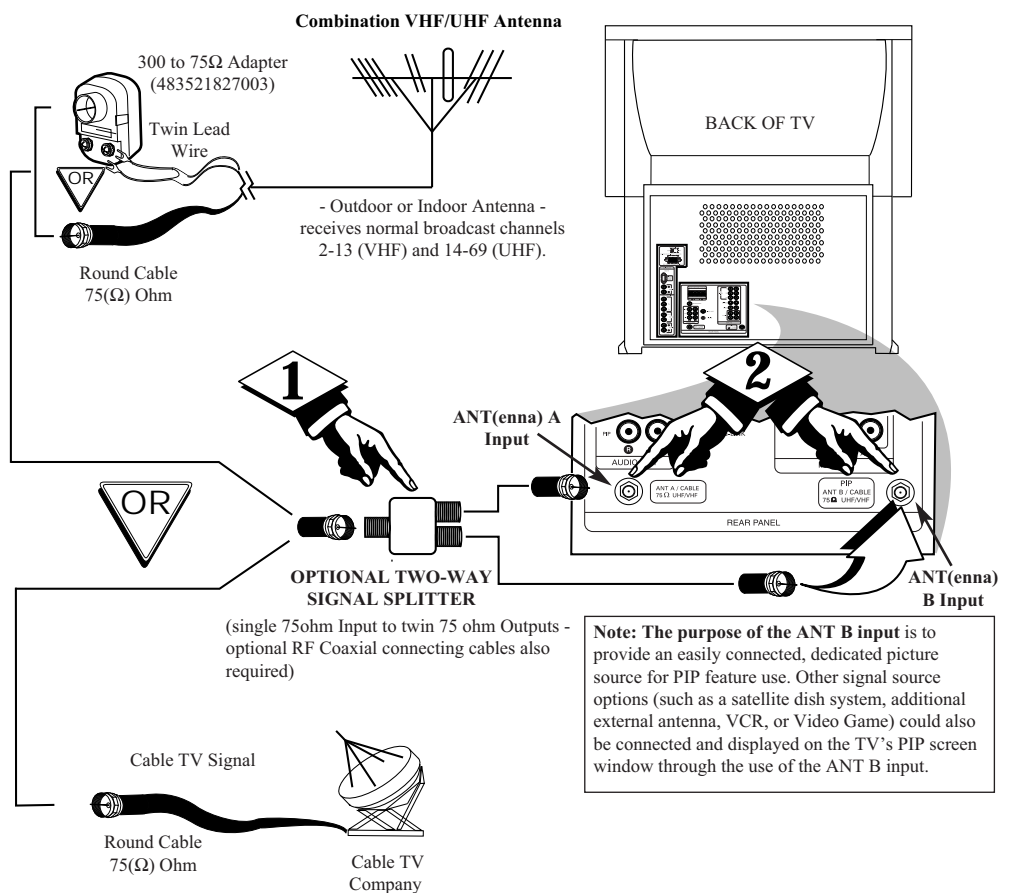
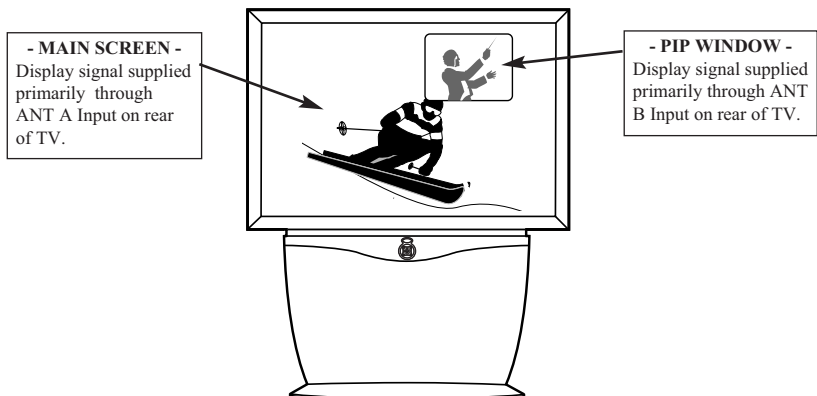

See the Set-Up Guide also provided with your TV set for further Cable TV connection options and accessories.

Now that you have completed the required connections on the previous page you are ready to follow the simple steps shown below.

**3 Turn the TV ON.**

**Place the TV's PIP SOURCE SELECT control to "ANT B"-**

- Press the PIP Source (D7 - LCD PIP Display) button on the remote to select "ANT B" as the PIP source, (or use the FEATURES MENU 4 of 5 control screen to select the PIP Source Select item as ANT B.

**Also be sure the TV's Main screen PICTURE SOURCE SELECT control is "ANT A"-**

- Use the remote's A/V button to set the TV to ANT A mode.

**Press the STATUS button** to clear the screen when the above Menu items have been set.

**4 Press the PIP ON/OFF (D1 - LCD PIP Display) button on the remote.**

The PIP window will show in one of the corners of the TV screen.

**5 Press the SWAP (D2 - LCD PIP Display) button on the remote to move the ANT B and ANT A Input pictures between the PIP window and Main screen.**

Use the PIP CH(annel) Up (+) and Down (-) (D5 and D6 - LCD PIP Display) buttons to select desired programs for viewing in the PIP window. Program Sound occurs with the channels displayed on the Main screen.

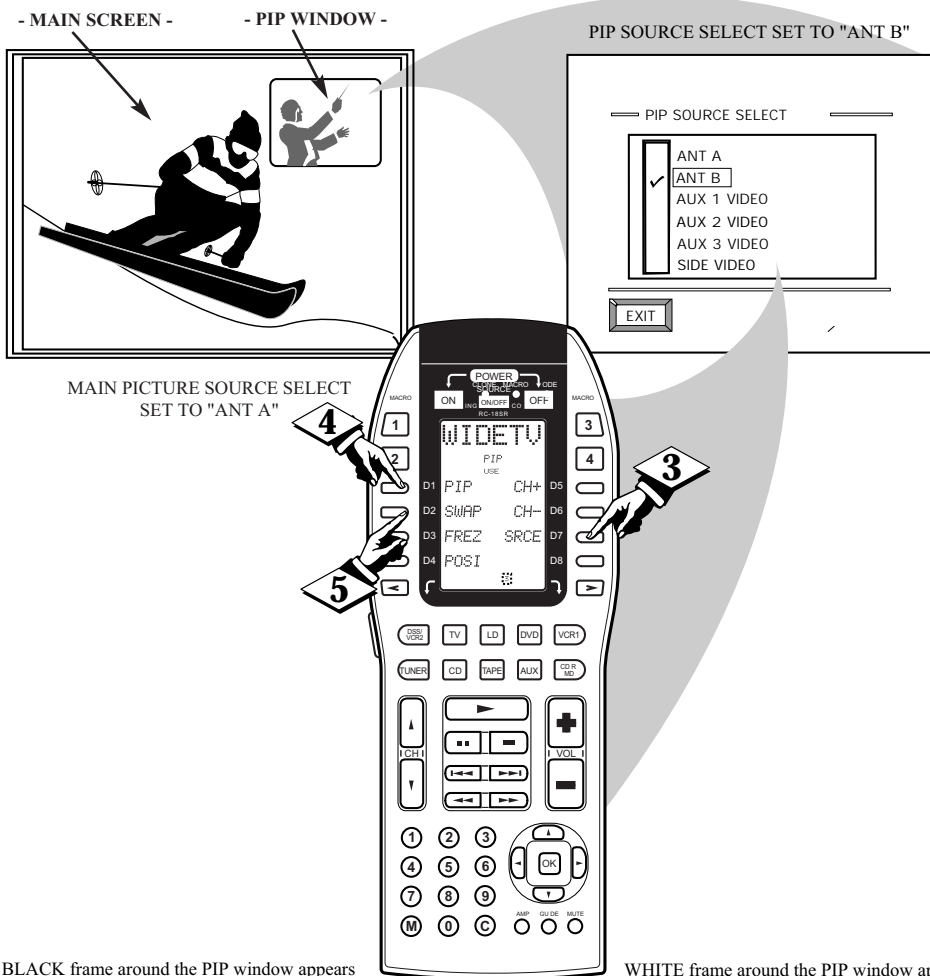

BLACK frame around the PIP window appears when the ANT A Input is on the Main screen.

WHITE frame around the PIP window appears when the ANT B Input is on the Main screen.

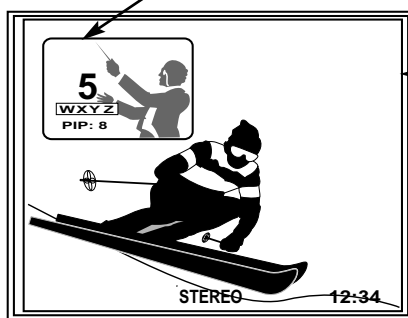

- Main Screen is CH 5 from ANT A input.
- PIP is CH 8 from ANT B input

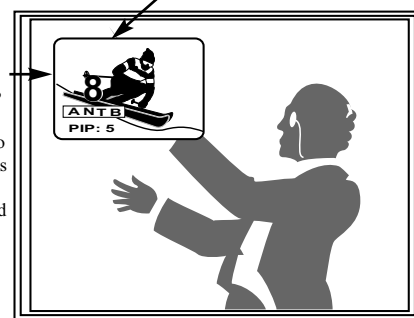

- Main Screen shows CH 8 from ANT B input.
- PIP is CH 5 from ANT A input.

Press SWAP (D2 - LCD PIP Display) button on the remote to switch programs shown on the Main screen and in the PIP window.

**SMART HELP**

Remember, if you see the same picture on the main screen and in the PIP window, check to be sure the TV's PIP Source Select and Main screen Picture Source select are set for ANT B and ANT A respectively. See the following page on how to operate other PIP features with the TV's remote control.

**NOTE:** Sound for TV programs displayed in the PIP window can also be heard through the use of PIP AUDIO OUT jacks on the rear of the TV. Just connect the TV's Left/Right PIP AUDIO OUTPUTs to the correct AUX(iliary) Inputs on an external stereo sound system (through which the PIP audio will be played).

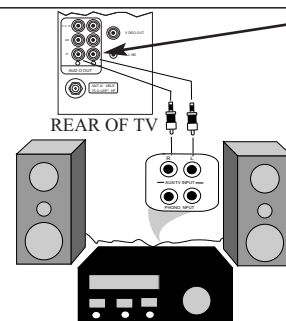

**PIP AUDIO OUTPUT** will be monaural (mono) when both ANT A and ANT B are being used for normal PIP operation. See page 30 for details on other stereo sound uses for the PIP Audio Output jacks.

# USING PIP WITH THE REMOTE CONTROL

By using the PIP buttons (D1 D7) on the remote (LCD PIP Display) the PIP picture can be moved and swapped with the main TV screen. The main screen picture can also be frozen in the PIP window.

## BEGIN

**1** Press the PIP ON/OFF (D1) button to show the PIP picture.

PIP appears in a corner of TV screen. Press PIP ON/OFF again to remove PIP from the main screen.

**2** With PIP on the TV screen, press the SWAP (D2) button to swap the main screen picture with the PIP picture. See "Smart Help" note on this page.

**3** Press FREEZE (D3) to hold the current MAIN screen picture in the PIP window (Main picture is still active).

If PIP is currently OFF, the PIP window will automatically appear.

Press FRZ repeatedly to update the frozen PIP with current pictures from the Main screen.

You cannot reposition a frozen PIP picture.

Press the PIP ON/OFF button to drop the frozen PIP picture from the screen.

**4** Press the PIP POSITION (D4) button to move the PIP picture (from corner-to-corner on the TV screen.)

This feature allows you to move PIP and avoid blocking off any main screen action.

**5** Press the PIP SOURCE (D7) button to change the signal input source (ANT B, etc.) for the PIP window shown on the TV screen.

Press the PIP CH(annel) Up (+) and Down (-) (D5 and D6) buttons to select channels shown within the PIP window (when an antenna/cable signal source is connected for use with PIP).



1. PIP ON / OFF

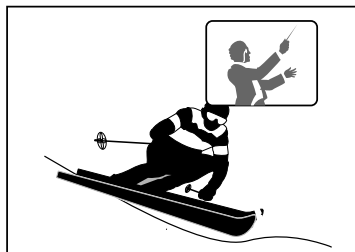

2. PIP SWAP

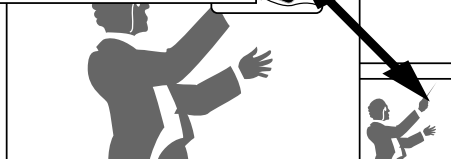

3. PIP FREEZE

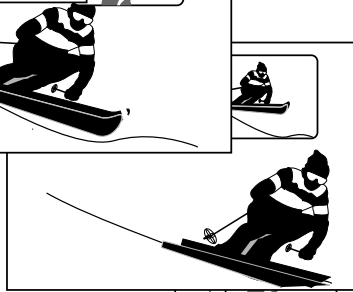

4. PIP POSITION



5. PIP SOURCE & PIP CH UP/DN



Note: Use the CH(annel) + and CH - (D5 and D6) buttons on the remote display to change the channels within the PIP window.

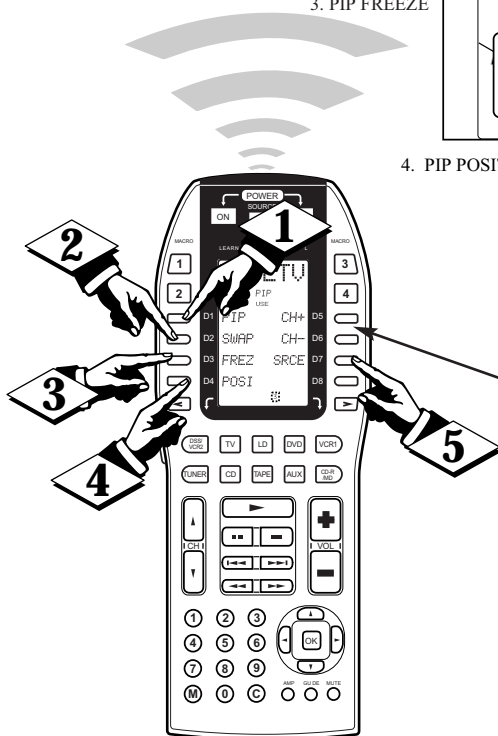

## SMART HELP



Remember, if the TV's Main screen picture is being supplied by an AUX VIDEO connected VCR (or other external accessory source); and then both the TV and VCR are turned OFF, a blank screen will appear when the TV is turned back ON again. If this happens, just reselect the TV's ANT A source mode to return to normal TV viewing.

# SELECTING THE PICTURE SOURCE FOR PIP

## PIP SOURCE

The picture for the PIP window can come through either the ANT(enna) A / B Inputs or the AUX Video Inputs (on the rear and side of the TV). PIP Picture Source simply tells the TV which one of these sources it is to show in the PIP window.

### BEGIN

#### 1 Select PIP SOURCE control.

With FEATURES MENU (4 of 5) on screen, move the RED highlight with the outer OK arrow buttons. Then press the center OK button to select the feature.

Note: The remote control's PIP SOURCE (D7 on LCD PIP Display) button can also be used to quickly select picture source inputs on the rear of the TV for the PIP window.

#### 2 Press the OK arrow and center OK buttons to highlight and select the desired PIP Picture Source.

**ANT A or B-** for a picture signal coming from either the ANT(enna) A or B Input plug on the TV.

**AUX 1 (or 2) VIDEO -** for a picture signal coming from the AUX 1 (or 2) VIDEO IN jack on the rear of the TV.

**AUX 3 VIDEO -** for a picture signal coming from the SIDE VIDEO Input jack on the right side of the TV cabinet.

#### 3 Press the STATUS (D5 on Mode 1 LCD Display) button to clear the screen.

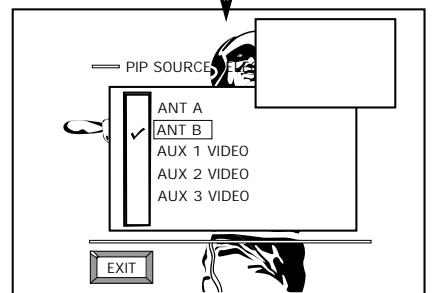
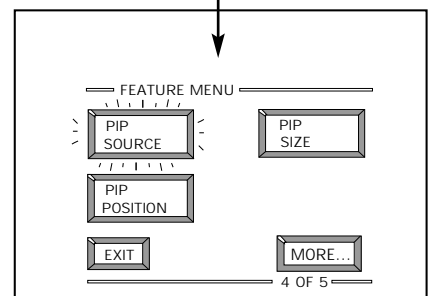
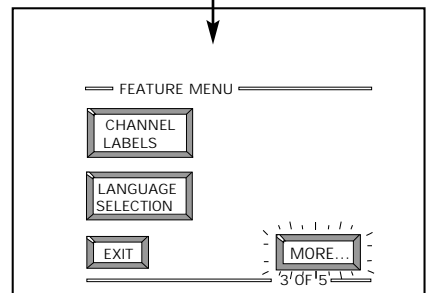
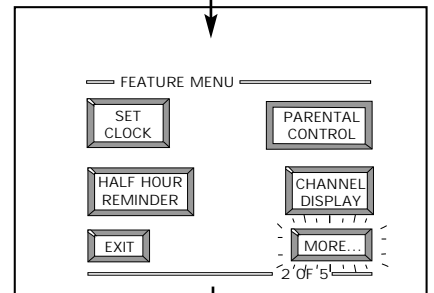
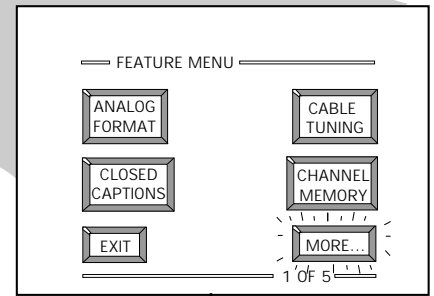
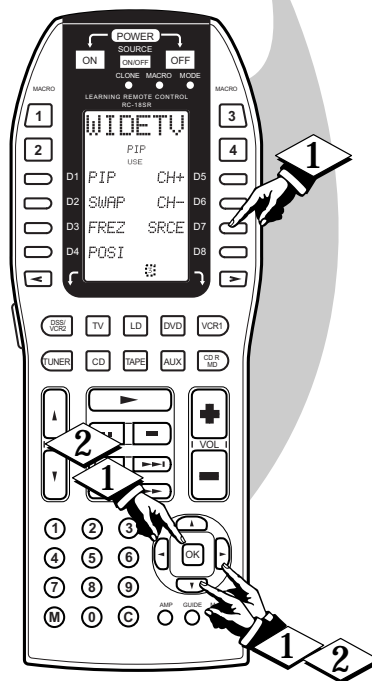
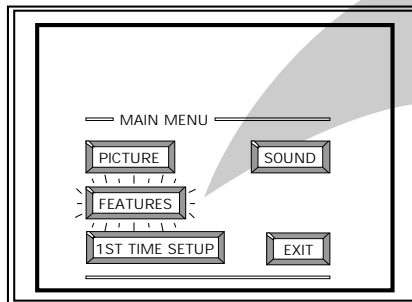

## SMART HELP



Remember, the PIP window will be blank unless a signal is connected to the selected PIP Picture Source (ANT B, AUX 1 VIDEO, AUX 2 VIDEO, etc.) on the set.

If you see the same picture on the main screen and in the PIP window, you may have the Main Screen and PIP window set to the same video input source.

# ADJUSTING PICTURE-IN-PICTURE COLOR AND TINT

## PIP COLOR / PIP TINT

The Picture In Picture (PIP) Color and Tint controls are used to make fine tune adjustments to the color settings for PIP (when it is shown on the TV screen).

### BEGIN

- 1 Select PIP COLOR (or PIP TINT) control.

With FEATURES MENU (5 of 5) on screen, move the RED highlight with the outer OK arrow buttons. Then press the center OK button to select the feature.

- 2 Press the outer OK arrow buttons to move the RED highlight. Press the OK button to turn (✓) the PIP COLOR or TINT control ON.

The PIP automatically comes on to show the PIP window on the TV screen.

- 3 Press the outer OK arrow (Left and Right) buttons to adjust the PIP for Color (or Tint) levels you prefer.

- 4 Press the STATUS button to clear the screen.



## SMART HELP



Remember. Although there are separate COLOR and TINT controls for PIP, the adjustment levels for these controls depend on the TV's main picture. For example: If the main screen is showing a black and white picture, PIP would also be in black and white (even though its source is in color).

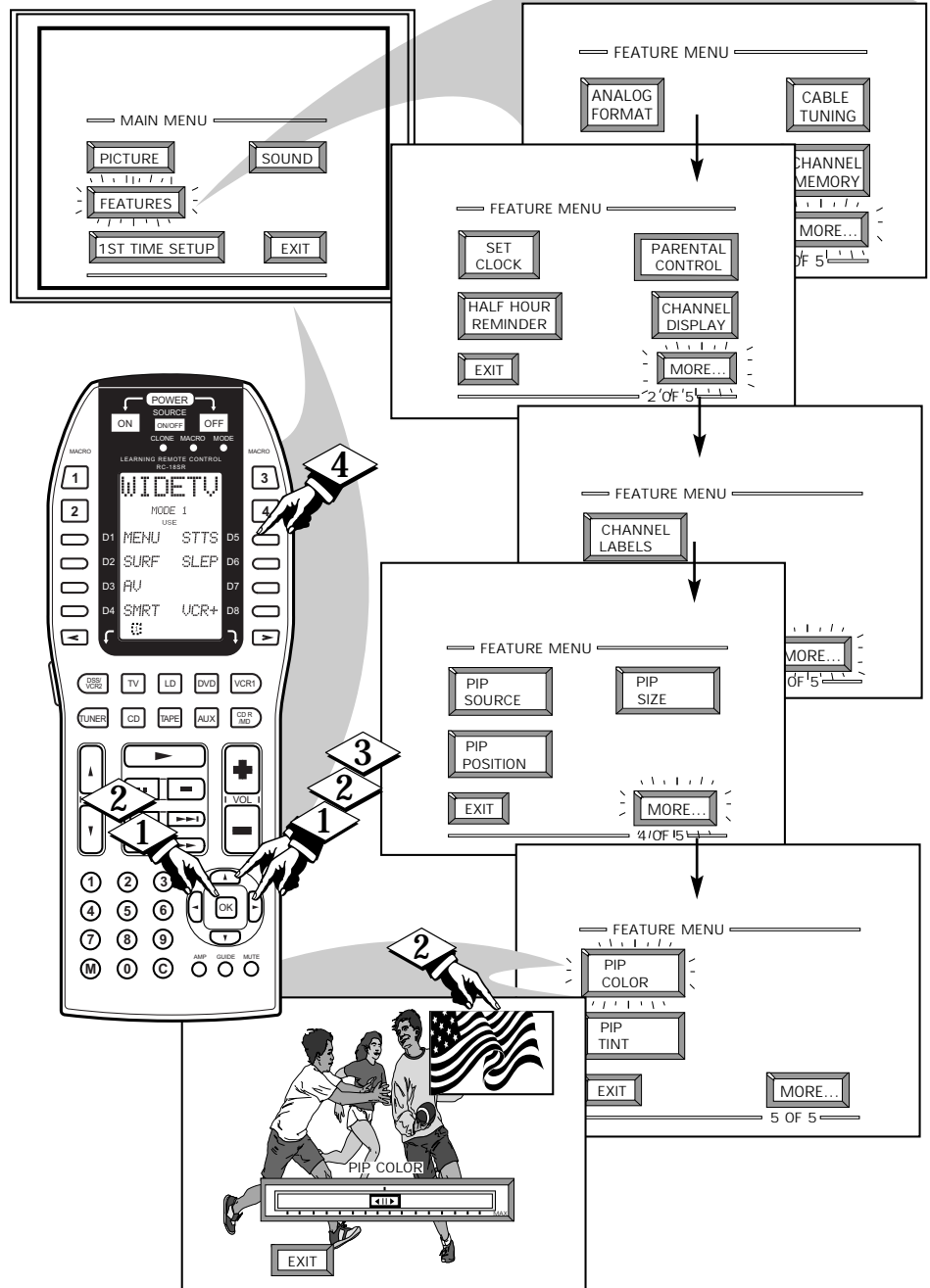

Note: The PIP SIZE Menu option can be used to change the size of the PIP window shown on the TV screen. Compare the Large and Small size displays to see which size you prefer for onscreen PIP use. (You cannot change the size of a frozen PIP picture.)

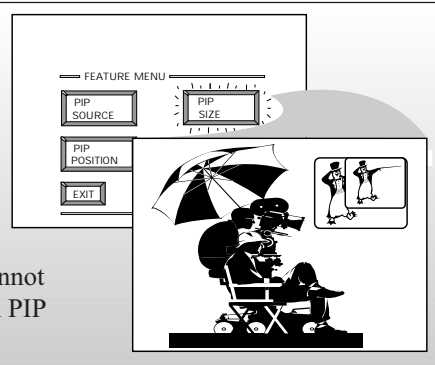



# MORE PIP CONNECTIONS



**SMART HELP** 

Remember to use the Cable TV Converter Box to select channels for PIP, the VCR must be set to the same channel as the channel selection switch on the rear of the Cable Converter (either channel 3 or 4).

The following example is for an alternative PIP connection hookup using an external Cable Converter Box and a VCR (as the picture source for the PIP window).

**BEGIN**

- 1 First use an optional signal splitter and connect the original cable TV signal to both the CABLE IN on the Cable Converter and the ANTENNA A plug on the rear of the TV.
- 2 Connect the CABLE OUT on the Converter to the ANT. IN on the VCR.
- 3 Connect the VIDEO OUT jack on the VCR to the VIDEO IN jack on the TV.  
Also connect the AUDIO OUT (R and L) jacks from the VCR to the AUDIO IN jacks on the TV.

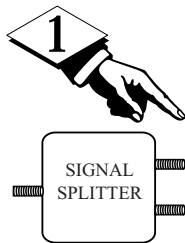

Contact the Parts Information Center 1 800 851-8885 to order any optional accessories

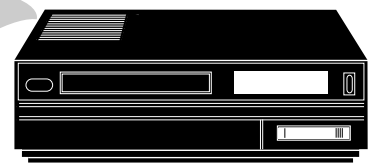
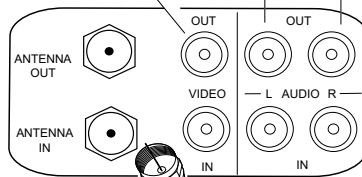

VCR

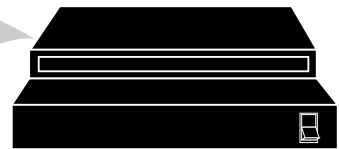
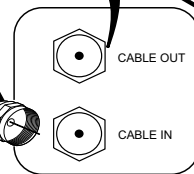

CABLE TV CONVERTER

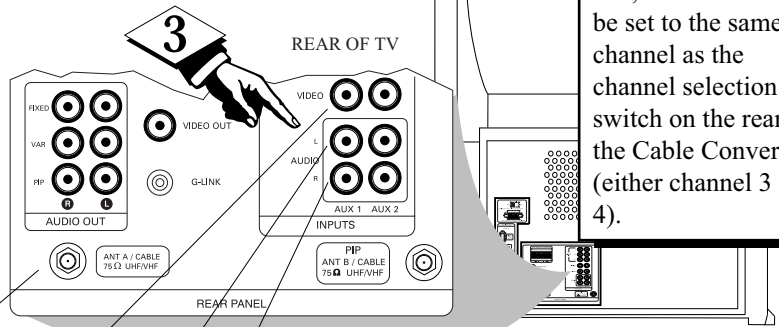

The ANTENNA A signal input supplies the TV's Main screen picture, and the AUX 1 VIDEO Input connection from the VCR serves as the picture source for PIP. Be sure to set the TV's PIP SOURCE SELECT control to the "AUX 1 VIDEO" mode in order to display the Audio/Video Input signals within the PIP window.

AUDIO VIDEO CABLES (RCA Plug Cables - optional)



## TIPS IF SOMETHING ISN'T WORKING

*Please make these simple checks before calling for service. These tips can save you time and money since charges for TV installation and adjustment of customer controls are not covered under your warranty.*

### No Power

### No Picture

### No Sound

### Remote Does Not Work

### TV Displays Wrong Channel or No Channels Above 13

CAUTION: A video source (such as a video game, Compact Disc Interactive - CDI, or TV information channel) which shows a constant non-moving pattern on the TV screen, can cause picture tube damage. When your TV is continuously used with such a source the pattern of the non-moving portion of the game (CDI, etc.) could leave an image permanently on the picture tube. When not in use, turn the video source OFF. Regularly alternate the use of such video sources with normal TV viewing.

- Check the TV power cord. Unplug the TV, wait 1 minute, then reinsert plug into outlet and push POWER button again.
- Check to be sure outlet is not on a wall switch.

- Check antenna connections on the rear of the TV. Are they properly secured to the antenna plug on the TV?
- Check the CABLE TUNING control for correct position.
- Check Picture Source (A/V Button) for correct position ANT A or B; AUX 1/2/3 VIDEO; AUX 1/2 Y PB PR; etc. position without a signal source will result in a blank screen.
- Check the CLOSED CAPTIONS control. Some TEXT modes could block the screen.

- Check the VOLUME and MUTE buttons on the TV and remote.
- Check the TV SPEAKER NORMAL/OFF sound control for the correct position.
- If attempting auxiliary equipment hook-ups, check audio jack connections and that the auxiliary equipment is on and in the proper operating modes.
- Check AMP Switch on rear of TV. Place in INT(ernal) position for normal TV sound. EXT(ernal) for optional Dolby ProLogic Surround Sound connections using the TV's speakers as Center channel.

- Check Product "System" buttons on the remote. Press the remote's TV System button to send commands to the TV; VCR System to send to VCR; etc. Check the separate Remote Control Owner's Manual for further operation details.
- Check batteries. Replace with AA Heavy Duty (Zinc Chloride) or Alkaline batteries if necessary.
- Clean the remote and the remote sensor window on the TV.

- Repeat channel selection.
- Add desired channel numbers (ADD/DELETE CHANNELS control) into TV memory.
- Check CABLE TUNING control for correct position.

This TV is equipped with protective circuitry that shuts the TV off in case of moderate power surges. Should this occur turn the TV back on by pressing the POWER button once or twice, or unplug and then replug the power cord at the AC outlet. This feature is NOT designed to prevent damage due to high power surges such as those caused by lightning, which is not covered by your warranty.

### Cleaning and Care

- To avoid possible shock hazard be sure the TV is unplugged from the electrical outlet before cleaning.
- When cleaning the TV screen take care not to scratch or damage the screen surface (avoid wearing jewelry or using anything abrasive- do not use household cleaners). Wipe the front screen with a clean cloth dampened with water. Use even, easy, vertical strokes when cleaning.
- Specially designed screen cleaning kits are also available which contain anti-static cleaners and cloths designed to get into the ridges of the TV screen. If interested, ask your dealer about an optional Projection TV Screen Cleaning Kit or call our toll-free Accessory Parts ordering number 1-800-851-8885.
- Gently wipe the cabinet surfaces with a clean cloth or sponge dampened in a solution of cool clear water and a mild soap or detergent. Use a clean dry cloth to dry the wiped surfaces.
- Occasionally vacuum the ventilation holes or slots in the cabinet back.
- Never use thinners, insecticide sprays, or other chemicals on or near the cabinet, as they might cause permanent marring of the cabinet finish.



**Aspect Ratio** \* The proportions of a rectangular display screen. NTSC television has a 4:3 ratio; HDTV is 16:9.

**Audio/Video Inputs** \* Located on the rear of the TV these connectors (RCA phono type plug) are used for the input of audio and video signals. Designed for use with VCRs (or other accessories) in order to receive higher picture resolution and offer sound connection options.

**Coaxial Cable** \* A single solid antenna wire normally matched with a metal plug (F-type) end connector that screws (or pushes) directly onto a 75 Ohm input found on the Television or VCR.

**Display** \* An on screen message or graphics that help the user operate and adjust TV feature controls. See On Screen Displays (OSD).

**HDTV** \* High Definition Television which offers approximately twice the vertical/horizontal resolution of NTSC video, and sound quality approaching that of compact disc. (Usually taken to mean a picture of 1920 x 1080 pixels in a 16:9 aspect ratio.)

**Identify** \* Method by which a remote control searches and finds an operating code for another product (such as a VCR or Cable Converter). Once the code has been "identified" then the TV remote can operate and send commands to the other product.

**LED** \* Light Emitting Diode or indicator.

**Menu** \* An on-screen listing of feature controls shown on the TV screen that are made available for user adjustments.

**Multichannel Television Sound (MTS)** \* The broadcast standard that allows for stereo sound to be transmitted with the TV picture.

**NTSC** \* National Television Standards Committee format devised for TV broadcasting signals in the 1940s (525 lines; 30Hz.)

**On Screen Displays (OSD)** \* Refers to the wording or messages generated by the TV to help the user with specific feature controls (color adjustment, programming, etc.).

**Picture -In-Picture (PIP)** \* Term used when two pictures are shown on the TV screen at the same time. The smaller PIP picture is supplied by a VCR (or other tuner/video playback source). The PIP picture can also be moved and swapped with the TV's main screen picture.

**Programming** \* The procedure of adding or deleting channel numbers into the TV's memory circuits. In this way the TV "remembers" only the locally available or desired channel numbers and skips over any unwanted channel numbers.

**Remote Sensor Window** \* A window or opening found on the TV control panel through which infrared remote control command signals are received.

**RGB** \* Red, Green, Blue color component inputs used for connection purposes with personal computers (PCs) and other high definition video devices.

**RF** \* Radio Frequency or modulated signal design used as the carrier for television broadcasts.

**Second Audio Program (SAP)** \* Another or additional audio channel provided for in the Multichannel Television Sound (MTS) broadcast standard. A monaural soundtrack included within the recorded or video signal (usually containing a second language translation for the displayed programming.)

**Status** \* Allows the user to quickly confirm what channel number is currently being viewed. Status can also be used to clear the TV of on-screen displays or information (rather than waiting for the displays to "time out" or automatically disappear from the screen).

**SVGA** \* Super Video Graphics Array

**S-Video Input** \* Allows direct connection of high-resolution video sources, such as a Super VHS videocassette recorder, Laser Disc player, etc. Provides improved picture resolution, sharpness, and clarity.

**Twin Lead Wire** \* The more commonly used name for the two strand 300 Ohm antenna wire used with many indoor and outdoor antenna systems. In many cases this type of antenna wire requires an additional adapter (or balun) in order to connect to the 75 Ohm Input terminals designed into the more recent Televisions and VCRs.

**Variable Audio Output** \* An adjustable audio output which allows for volume variations at the source.

**VGA** \* Video Graphics Array



# INDEX

Accessories/Optional.....	33-37, 38, 44, 49, *Q/U-1
Add/Delete Channels .....	13-14, *Q/U-2
Audio Controls .....	27-32
Audio/Video Input .....	33-37, 44, 49, *Q/U-2
Automatic Programming .....	13, *Q/U-2
Auto Picture.....	40-41
Auto Sound .....	42
Auto Surf .....	43
Battery Installation .....	*Q/U-3
Blocking Channels .....	19-20
Cable TV Connections/Settings .....	12, 44, 49 *Q/U-1, 2
Channel/Time Display .....	15, 16, 17, *Q/U-3
Channel Label.....	25
Channel Memory.....	13-14, *Q/U-2
Channel/Time Reminder.....	18
Clock Setting .....	15
Closed Captioning .....	11
Content Advisory .....	19-24
Convergence .....	8
Controls/TV.....	*Q/U-2, 3, 4
Controls/Remote .....	40-43, 46, *Q/U-2, 3, 4
Exit .....	*Q/U-4
Features.....	5
First Time Set Up .....	*Q/U-2
Inputs/Audio and Video .....	33-37, 44, 49
Language.....	26, 39
Menu.....	*Q/U-2, 4
Minus(-)/Plus (+) Buttons.....	*Q/U-3, 4
Monitor HD Features.....	38-39
Movie Ratings .....	21-22
Parental Control.....	19-24
Parental Guidelines.....	23
Picture-In-Picture (PIP).....	44-49, *Q/U-2
PIP Audio Output jacks.....	30-31, 45
Programming Channels .....	13, *Q/U-2
Remote Control .....	40-43, 46, *Q/U-2, 3, 4
Requesting Service .....	50, 53-54, 56
Reminder/Time and Channel.....	18
Safety/Precautions .....	2, 3, 50, *Q/U-1
Second Audio Program (SAP).....	28
Sensor Remote.....	*Q/U-3
Sleep Timer.....	16
Surround Sound.....	31-32
Speaker Terminals .....	31
Time/Channel Display.....	18, *Q/U-3
Variable Audio Output .....	31, 39
Video Enhancement.....	7
VCR/TV Connections .....	33-37, 44, 49, *Q/U-1
Tips for Service .....	50, 53-54
TV Speaker Control.....	30, 39
Volume Display .....	29, 39
Warranty .....	53

\* Q/U indicates page number reference in the separate Quick Use Guide

**RENEWED  
90 DAY  
LIMITED WARRANTY**